



Relays for advanced technology

ULTRA-MINIATURE PC BOARD TYPE POWER RELAY

SFK-RELAY



UL,C-UL File No.:E179745
TUV File No.:40007481
CQC File No.:CQC02001002131

- Ideal for motor switching.
- Miniature relay with high swithing capacity built-in applications.
- Highly noise-resistive insulation materials employed.
- Standard model available with flux protection construction.

SPECIFICATIONS

Contact

Arrangement	1a	
Contact material	Silver alloy	
Contact resistive (By voltage drop 1A 6VDC)	50mΩ Max.	
UL/C-UL rating Resistive load (cos φ =1)	20A	250VAC
VDE rating	20A	250VAC
CQC rating	20A/80A	250VAC
Max.switching voltage	250VAC	
Max.switching current	20A	
Max.switching power	5,000VA	
Exoected life(min.ope)	Mechanical (at 120cpm)	1X10 ⁷
	Electrical (at 20 cpm)	1X10 ⁵

Characteristics

Operate time	20 msec.Max.	
Release time	10 msec.Max.	
Initial breakdown voltage	Between contact and coil	4,500VAC (50/60Hz) for 1 min.
	Between open contacts	1,500VAC (50/60Hz) for 1 min.
Insulation resistance	1,000MΩ Min.(500VDC)	
Ambient temperature	-30℃ ~ +70℃	
Unit weight	Approx. 23g	

Coil

Nominal operating power	0.9W
-------------------------	------

TYPICAL APPLICATION

- 1.Ideal for motor switching
- 2.Demestic and industry appliances.

ORDERING INFORMATION

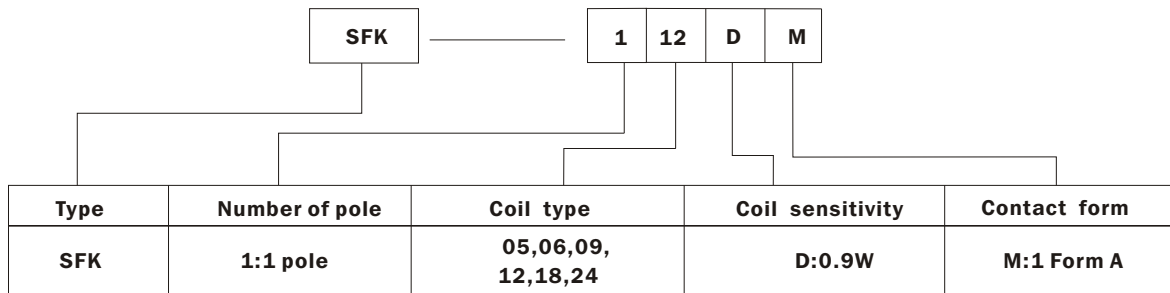

COIL(at 20°C)

SFK

Voltage code	Nominal voltage (VDC)	Nominal current (mA)	Coil resistance ($\Omega \pm 10\%$)	Drop-out voltage (VDC)	Pick-up voltage (VDC)	Nominal operating power (W)	Max allowable voltage (VDC)
05	5	178.57	28	5%Min.	75%Max.	0.9	110% of nominal voltage
06	6	150.00	40				
09	9	100.00	90				
12	12	75.00	160				
18	18	50.00	360				
24	24	37.50	640				

OUTLINE DIMENSIONS, WIRING DIAGRAM AND PC BOARD LAYOUT(unit:mm)

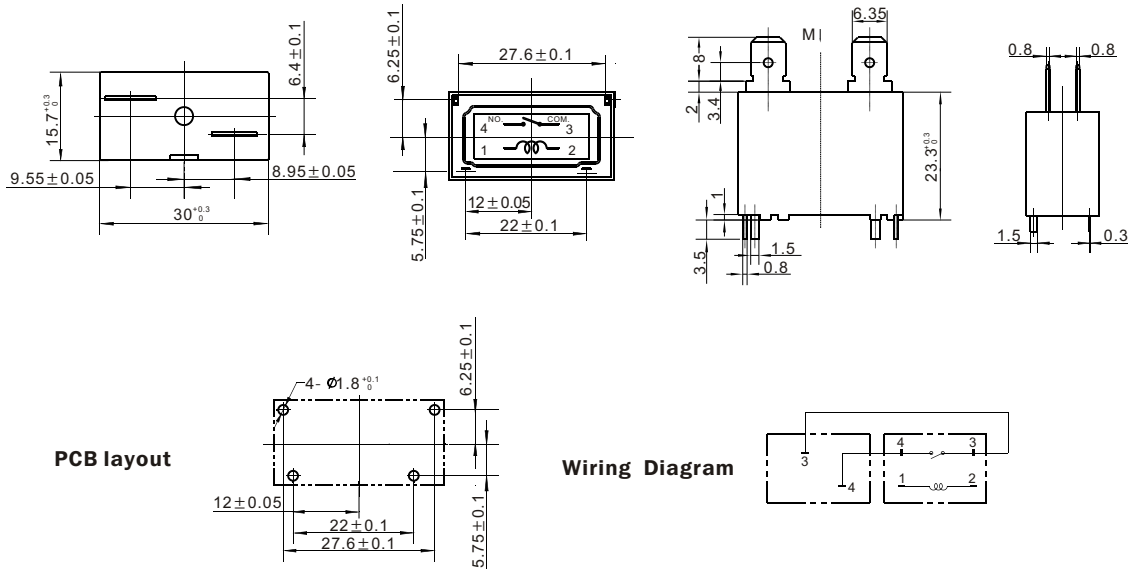

CHARACTERISTICS CURVE

