



# FXTE01 and FXTE02 User Guide

## AirLink FXT Series



**SIERRA**  
WIRELESS

WA\_DEV\_FEX20\_UGD\_008  
001  
July 02, 2010

## Important Notice

Due to the nature of wireless communications, transmission and reception of data can never be guaranteed. Data may be delayed, corrupted (i.e., have errors) or be totally lost. Although significant delays or losses of data are rare when wireless devices such as the Sierra Wireless modem are used in a normal manner with a well-constructed network, the Sierra Wireless modem should not be used in situations where failure to transmit or receive data could result in damage of any kind to the user or any other party, including but not limited to personal injury, death, or loss of property. Sierra Wireless accepts no responsibility for damages of any kind resulting from delays or errors in data transmitted or received using the Sierra Wireless modem, or for failure of the Sierra Wireless modem to transmit or receive such data.

## Safety and Hazards

Do not operate the Sierra Wireless modem in areas where blasting is in progress, where explosive atmospheres may be present, near medical equipment, near life support equipment, or any equipment which may be susceptible to any form of radio interference. In such areas, the Sierra Wireless modem **MUST BE POWERED OFF**. The Sierra Wireless modem can transmit signals that could interfere with this equipment. Do not operate the Sierra Wireless modem in any aircraft, whether the aircraft is on the ground or in flight. In aircraft, the Sierra Wireless modem **MUST BE POWERED OFF**. When operating, the Sierra Wireless modem can transmit signals that could interfere with various onboard systems.

---

*Note: Some airlines may permit the use of cellular phones while the aircraft is on the ground and the door is open. Sierra Wireless modems may be used at this time.*

---

The driver or operator of any vehicle should not operate the Sierra Wireless modem while in control of a vehicle. Doing so will detract from the driver or operator's control and operation of that vehicle. In some states and provinces, operating such communications devices while in control of a vehicle is an offence.

## Limitations of Liability

This manual is provided "as is". Sierra Wireless makes no warranties of any kind, either expressed or implied, including any implied warranties of merchantability, fitness for a particular purpose, or noninfringement. The recipient of the manual shall endorse all risks arising from its use.

The information in this manual is subject to change without notice and does not represent a commitment on the part of Sierra Wireless. SIERRA WIRELESS AND ITS AFFILIATES SPECIFICALLY DISCLAIM LIABILITY FOR ANY AND ALL DIRECT, INDIRECT, SPECIAL, GENERAL, INCIDENTAL, CONSEQUENTIAL, PUNITIVE OR EXEMPLARY DAMAGES INCLUDING, BUT NOT LIMITED TO, LOSS OF PROFITS OR REVENUE OR ANTICIPATED PROFITS OR REVENUE ARISING OUT OF THE USE OR INABILITY TO USE ANY SIERRA WIRELESS PRODUCT, EVEN IF SIERRA WIRELESS AND/OR ITS AFFILIATES HAS BEEN ADVISED OF THE POSSIBILITY OF SUCH DAMAGES OR THEY ARE FORESEEABLE OR FOR CLAIMS BY ANY THIRD PARTY.

Notwithstanding the foregoing, in no event shall Sierra Wireless and/or its affiliates aggregate liability arising under or in connection with the Sierra Wireless product, regardless of the number of events, occurrences, or claims giving rise to liability, be in excess of the price paid by the purchaser for the Sierra Wireless product.

# Patents

Portions of this product may be covered by some or all of the following US patents:

5,515,013	5,629,960	5,845,216	5,847,553	5,878,234	5,890,057	5,929,815	6,169,884
6,191,741	6,199,168	6,339,405	6,359,591	6,400,336	6,516,204	6,561,851	6,643,501
6,653,979	6,697,030	6,785,830	6,845,249	6,847,830	6,876,697	6,879,585	6,886,049
6,968,171	6,985,757	7,023,878	7,053,843	7,106,569	7,145,267	7,200,512	7,295,171
7,287,162	D442,170	D459,303	D599,256	D560,911			

and other patents pending.

This product includes technology licensed from QUALCOMM® 3G



Manufactured or sold by Sierra Wireless or its licensees under one or more patents licensed from InterDigital Group.

# Copyright

© 2010 Sierra Wireless. All rights reserved.

# Trademarks

AirCard® and Watcher® are registered trademarks of Sierra Wireless. Sierra Wireless™, AirPrime™, AirLink™, AirVantage™ and the Sierra Wireless logo are trademarks of Sierra Wireless.

**wavecom**™, ™, ™, inSIM®, WAVECOM®, WISMO®, Wireless Microprocessor®, Wireless CPU®, Open AT® are filed or registered trademarks of Sierra Wireless S.A. in France and/or in other countries.

Windows® and Windows Vista® are registered trademarks of Microsoft Corporation.

Macintosh and Mac OS are registered trademarks of Apple Inc., registered in the U.S. and other countries.

QUALCOMM® is a registered trademark of QUALCOMM Incorporated. Used under license.

Other trademarks are the property of the respective owners.

# Contact Information

Sales Desk:	Phone:	1-604-232-1488
	Hours:	8:00 AM to 5:00 PM Pacific Time
	E-mail:	<a href="mailto:sales@sierrawireless.com">sales@sierrawireless.com</a>
Post:	Sierra Wireless 13811 Wireless Way Richmond, BC Canada V6V 3A4	
Fax:	1-604-231-1109	
Web:	<a href="http://www.sierrawireless.com">www.sierrawireless.com</a>	

Consult our website for up-to-date product descriptions, documentation, application notes, firmware upgrades, troubleshooting tips, and press releases: [www.sierrawireless.com](http://www.sierrawireless.com)

# Document History

Version	Date	Updates
001	July 02, 2010	Creation



# Contents

<b>1. OVERVIEW.....</b>	<b>11</b>
1.1. Expansion Card Description.....	11
1.1.1. FXTE01: IO+GPS Expansion Card .....	11
1.1.2. FXTE02: Ethernet Expansion Card .....	12
1.2. External Connections.....	13
1.2.1. FXTE01: IO+GPS Expansion Card .....	13
1.2.1.1. MMCX RF Connector .....	13
1.2.1.2. 16-way IO Socket .....	14
1.2.1.3. General Purpose Input/Output.....	15
1.2.2. FXTE02: Ethernet Expansion Card .....	15
1.3. 50-pin Expansion Card Connector .....	16
<b>2. EXPANSION CARD BASIC REQUIREMENTS.....</b>	<b>18</b>
2.1. FXTE01 Requirements .....	18
2.2. FXTE02 Requirements .....	18
<b>3. FEATURES AND SERVICES.....</b>	<b>19</b>
<b>4. TECHNICAL CHARACTERISTICS .....</b>	<b>20</b>
4.1. Mechanical Characteristics .....	20
4.2. Physical Dimensions.....	20
4.2.1. FXTE01: IO+GPS Expansion Card .....	20
4.2.2. FXTE02: Ethernet Expansion Card .....	21
<b>5. USING THE EXPANSION CARD .....</b>	<b>22</b>
5.1. Getting Started .....	22
5.1.1. Installing the Expansion Card.....	22
5.1.2. Expansion Card Quick Check .....	23
5.1.2.1. GPS Check (for FXTE01).....	24
5.1.2.2. Ethernet Check (for FXTE02).....	26
5.2. Expansion Card Operational Status .....	28
5.2.1. FXTE01: IO+GPS Expansion Card .....	28
5.2.2. FXTE02: Ethernet Expansion Card .....	28
<b>6. TROUBLESHOOTING THE EXPANSION CARD .....</b>	<b>29</b>
6.1. No Communications with the Expansion Card through the Serial Link .....	29
<b>7. FUNCTIONAL DESCRIPTION .....</b>	<b>31</b>
7.1. FXTE01: IO+GPS Expansion Card .....	31
7.1.1. Architecture .....	31
7.2. FXTE02: Ethernet Expansion Card .....	32
7.2.1. Architecture .....	32
7.3. Electrical Characteristics.....	32
7.3.1.1. Power Supply.....	32
7.4. Extra Current Consumption from the DC-IN Source .....	33

7.5.	Other Specifications.....	34
7.5.1.	FXTE01: IO+GPS Expansion Card .....	34
7.5.1.1.	GPS Receiver Frequency .....	34
7.5.1.2.	GPS RF Performance.....	34
7.5.1.3.	External Antenna.....	34
7.5.2.	FXTE02: Ethernet Expansion Card .....	35
7.5.2.1.	RJ45 Ethernet Interface Socket.....	35
<b>8.</b>	<b>RELIABILITY STANDARDS: COMPLIANCE AND RECOMMENDATIONS .....</b>	<b>36</b>
8.1.	Reliability Compliance.....	36
8.2.	Applicable Standards Listing.....	36
8.3.	Environmental Specifications .....	37
8.3.1.	Function Status Classification .....	37
8.3.2.	Reliability Prediction Model .....	38
8.3.2.1.	FXTE01 (IO+GPS Expansion Card) .....	38
8.3.2.2.	FXTE02 (Ethernet Expansion Card) .....	43
<b>9.</b>	<b>CERTIFICATION COMPLIANCE AND RECOMMENDED STANDARDS .....</b>	<b>47</b>
9.1.	Certification Compliance .....	47
9.2.	Applicable Standards Listing.....	47
<b>10.</b>	<b>CONNECTOR AND PERIPHERAL DEVICES REFERENCES .....</b>	<b>49</b>
10.1.	General Purpose Connector .....	49
10.2.	16-way I/O Socket (for FXTE01) .....	49
10.3.	16-way I/O Plug (for FXTE01) .....	49
10.4.	10-pin Socket (for FXTE02) .....	49
<b>11.</b>	<b>RECOMMENDED ACCESSORIES .....</b>	<b>50</b>
<b>12.</b>	<b>REFERENCE DOCUMENTS.....</b>	<b>51</b>
12.1.	Sierra Wireless Software Documentation .....	51
12.2.	Firmware Documentation.....	51
12.3.	AirLink FXT Series Documentation .....	51
12.4.	Expansion Card Documentation.....	51
<b>13.</b>	<b>LIST OF ABBREVIATIONS.....</b>	<b>52</b>
<b>14.</b>	<b>SAFETY RECOMMENDATIONS (FOR INFORMATION ONLY) .....</b>	<b>54</b>
14.1.	RF Safety .....	54
14.1.1.	General .....	54
14.1.2.	Exposure to RF Energy.....	54
14.1.3.	Efficient Terminal Operation.....	54
14.1.4.	Antenna Care and Replacement .....	54
14.2.	General Safety.....	55
14.2.1.	Driving.....	55
14.2.2.	Electronic Devices .....	55
14.2.3.	Vehicle Electronic Equipment.....	55
14.2.4.	Medical Electronic Equipment .....	55
14.2.5.	Aircraft.....	55

14.2.6.	Children.....	56
14.2.7.	Blasting Areas .....	56
14.2.8.	Potentially Explosive Atmospheres.....	56
<b>15.</b>	<b>APPENDIX A: PACKAGING .....</b>	<b>57</b>
15.1.	Contents.....	57
15.1.1.	FXTE01: IO+GPS Expansion Card .....	57
15.1.2.	FXTE02: Ethernet Expansion Card .....	58
15.2.	Packaging Box.....	59
15.3.	Production Stickers.....	59



## List of Figures

Figure 1.	FXTE01 – Top Side .....	11
Figure 2.	FXTE01 – Bottom Side .....	12
Figure 3.	FXTE02 – Top Side .....	12
Figure 4.	FXTE02 – Bottom Side .....	13
Figure 5.	MMCX Connector for Antenna Connection.....	14
Figure 6.	16-way IO Expander Socket .....	14
Figure 7.	10-pin Interface Socket .....	16
Figure 8.	50-pin Expansion Card Connector .....	17
Figure 9.	FXTE01 Physical Dimensions .....	20
Figure 10.	FXTE02 Physical Dimensions .....	21
Figure 11.	FXTE01 Running on Sierra Wireless Sample C-GPS Code.....	25
Figure 12.	FXTE02 Running on Sierra Wireless Sample Ethernet Code.....	26
Figure 13.	FXTE01 Architecture .....	31
Figure 14.	FXTE02 Architecture .....	32
Figure 15.	Product Name and Serial Number Sticker .....	59
Figure 16.	MAC Address Sticker.....	59



# List of Tables

Table 1:	16-way IO Expander Socket Pin Description .....	15
Table 2:	GPIO Pin Description.....	15
Table 3:	10-pin Interface Socket Pin Description.....	16
Table 4:	FXTE01 and FXTE02 Expansion Card Basic Features.....	19
Table 5:	Expansion Card Mechanical Characteristics.....	20
Table 6:	Enabling the Active Antenna Power Supply.....	25
Table 7:	Turning the Active Antenna Power Supply ON/OFF .....	25
Table 8:	Activating the Sierra Wireless Ethernet Sample Code .....	26
Table 9:	Activating or Deactivating the Ethernet Board .....	27
Table 10:	Setting the DHCP Address.....	27
Table 11:	Setting the Static IP Address.....	27
Table 12:	Setting the DNS IP Address for Static IP Option.....	27
Table 13:	Setting the Gateway IP Address for Static IP Option .....	27
Table 14:	Setting the Netmask IP Address for Static IP Option .....	27
Table 15:	FXTE01 Operational Status .....	28
Table 16:	FXTE02 Operational Status .....	28
Table 17:	No Communications with the Expansion Card Through the Serial Link.....	29
Table 18:	No Communications with FXTE01 Through the Serial Link.....	30
Table 19:	No Communications with FXTE02 Through the Serial Link.....	30
Table 20:	Electrical Characteristics.....	32
Table 21:	Ethernet Expansion Card Power Consumption.....	33
Table 22:	Extra Current Consumption from DC-IN Source for the FXTE01 (Typical Values).....	33
Table 23:	Extra Current Consumption from DC-IN Source for the FXTE02 (Typical Values).....	33
Table 24:	GPS Receiver Frequency .....	34
Table 25:	FXTE01 Receiver Performances.....	34
Table 26:	FXTE01 External Antenna Characteristics .....	34
Table 27:	RJ45 Pin Description .....	35
Table 28:	Standards Conformity for Expansion Cards.....	36
Table 29:	Applicable Standards and Requirements for Expansion Cards .....	36
Table 30:	Operating Class Temperature Range.....	37
Table 31:	ISO Failure Mode Severity Classification.....	38
Table 32:	Life Stress Test.....	38
Table 33:	Environmental Resistance Stress Tests .....	39
Table 34:	Corrosive Resistance Stress Test .....	39
Table 35:	Thermal Resistance Cycle Stress Test.....	40
Table 36:	Mechanical Resistance Stress Tests.....	40
Table 37:	Handling Resistance Stress Tests.....	42

---

Table 38:	Life Stress Test.....	43
Table 39:	Environmental Resistance Stress Tests .....	43
Table 40:	Corrosive Resistance Stress Test .....	44
Table 41:	Thermal Resistance Cycle Stress Test.....	44
Table 42:	Mechanical Resistance Stress Tests.....	45
Table 43:	Handling Resistance Stress Tests.....	46
Table 44:	Standards Conformity for the Expansion Card.....	47
Table 45:	Applicable Standards and Requirements for the Expansion Card .....	47
Table 46:	Recommended Accessories .....	50

# >> 1. Overview

The Expansion Card is a device that expands the functionality of a standard Fastrack Xtend programmable gateway into a state of the art device for machine to machine applications. With the Expansion Card, it is possible to utilize the Internal Expansion Socket (IES) which allows the Fastrack Xtend to have a bigger application potential.

The Expansion Card comes in two variants – the **FXTE01** which is an IO+GPS Expansion Card and the **FXTE02** which is an Ethernet Expansion Card.

The Fastrack Xtend with an Expansion Card plugged-in may utilize one or more AT Plug-Ins of the powerful Sierra Wireless Software Suite. The Sierra Wireless Software Suite is the world's most comprehensive cellular development environment, which allows embedded standard ANSI C applications to be natively executed directly on intelligent embedded modules.

Note that this document only covers functionalities of FXTE01 (IO+GPS Expansion Card) and FXTE02 (Ethernet Expansion Card) and does not include discussions on the programmable capabilities provided via the use of the Sierra Wireless Software Suite nor development guides for expanding the application feature through the IES interface. For more information about the Sierra Wireless Software Suite, refer to the documents listed in section 12 Reference Documents.

## 1.1. Expansion Card Description

### 1.1.1. FXTE01: IO+GPS Expansion Card

The following figure shows the top and bottom views of the IO+GPS Expansion Card.

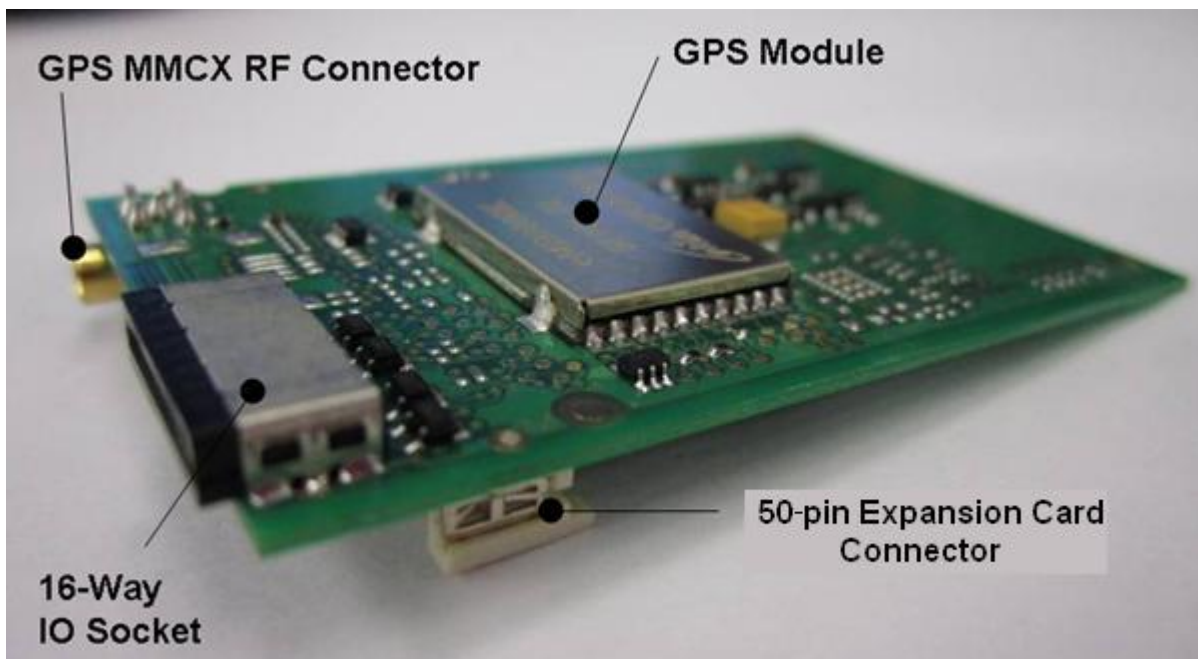

Figure 1. FXTE01 – Top Side

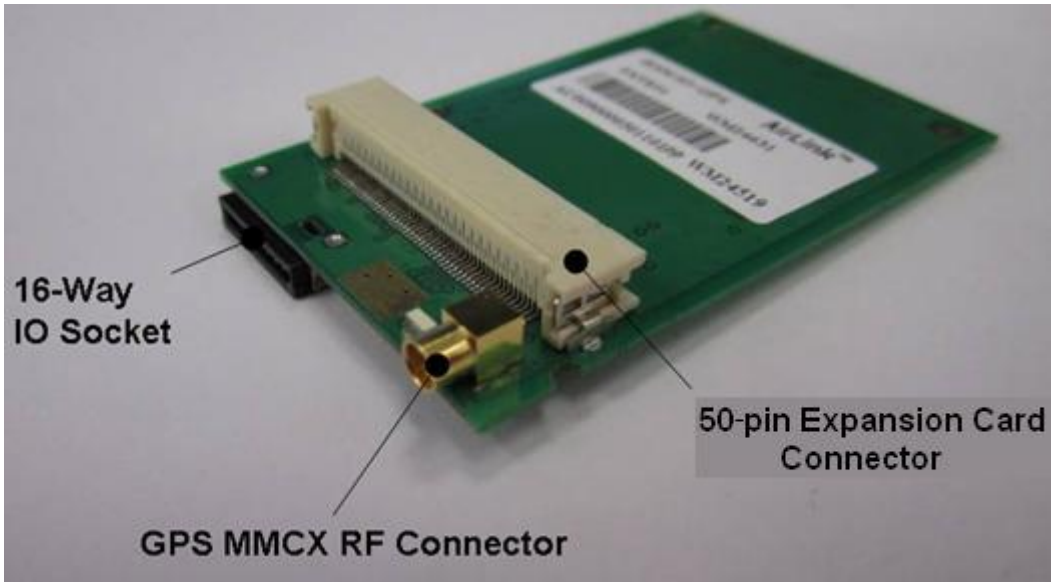

Figure 2. FXTE01 – Bottom Side

### 1.1.2. FXTE02: Ethernet Expansion Card

The following figure shows the top and bottom views of the Ethernet Expansion Card.

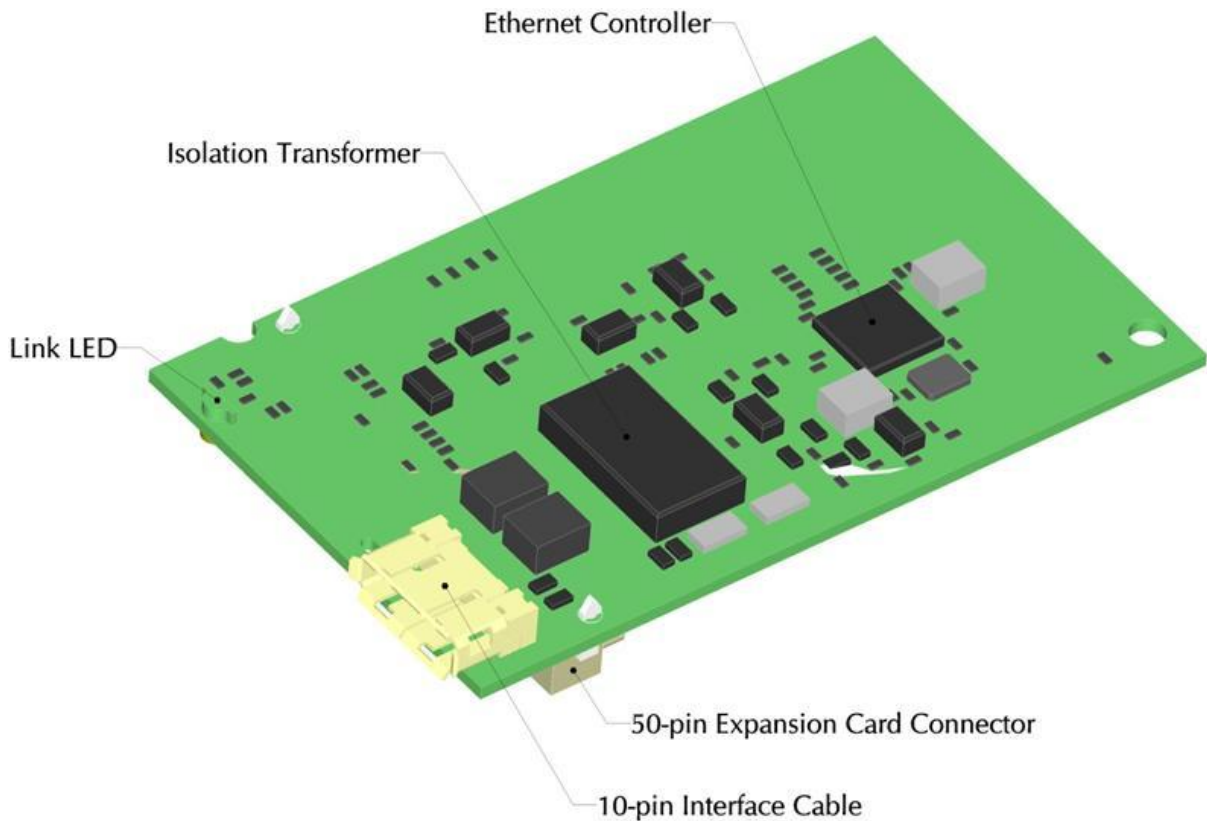

Figure 3. FXTE02 – Top Side

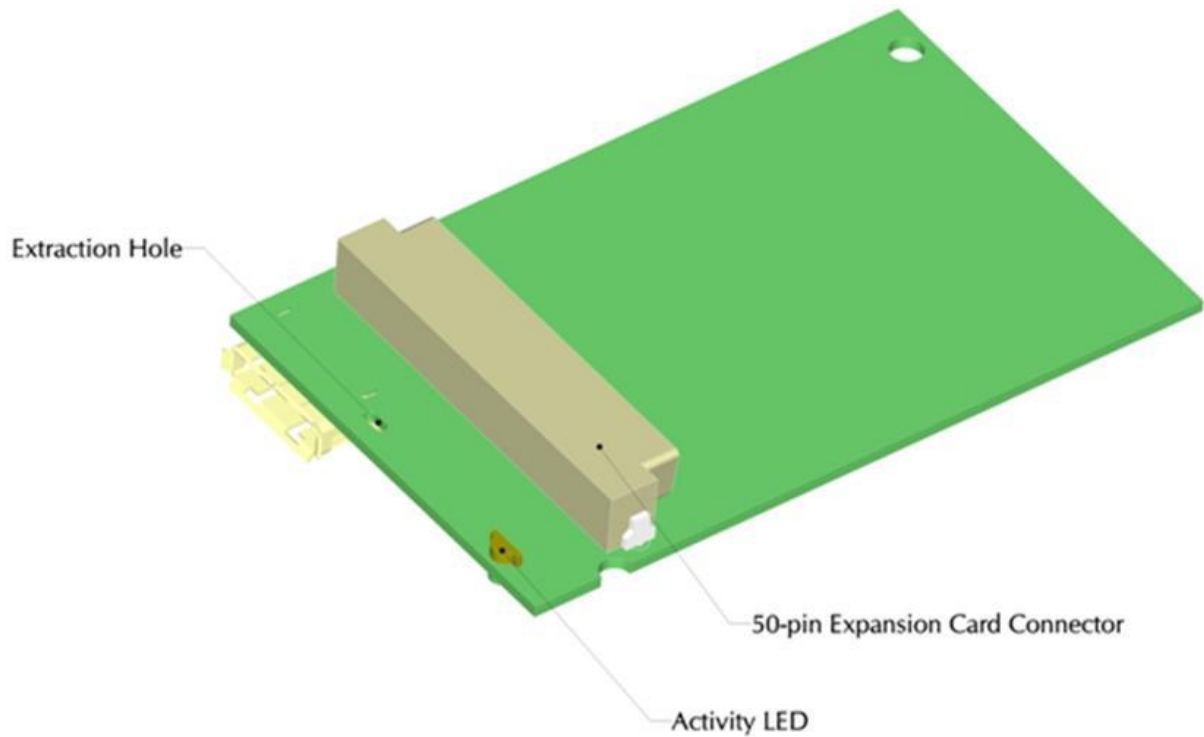

Figure 4. FXTE02 – Bottom Side

## 1.2. External Connections

### 1.2.1. FXTE01: IO+GPS Expansion Card

The FXTE01 has two external connections – the MMCX RF connector and the 16-way IO socket.

#### 1.2.1.1. MMCX RF Connector

The GPS antenna connector is an MMCX type connector for a 50 $\Omega$  RF connection. 3.3VDC is available on this connector for supplying GPS active antennas. This supply can be turned ON or OFF using AT Command.

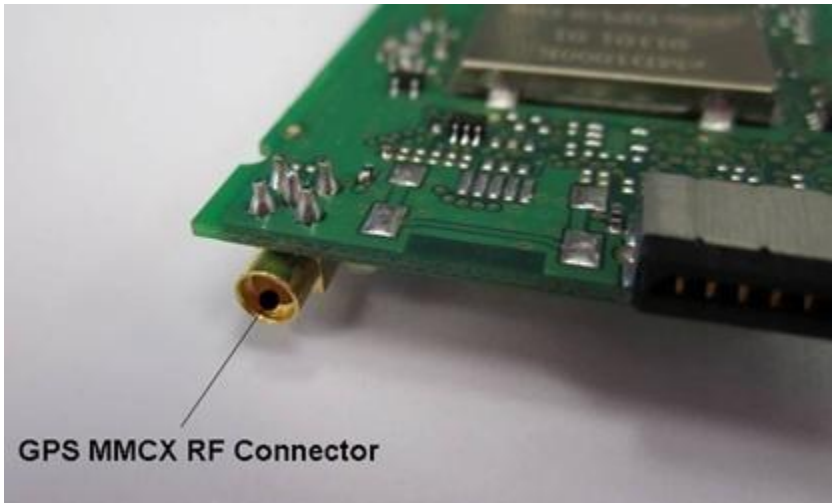

Figure 5. MMCX Connector for Antenna Connection

### 1.2.1.2. 16-way IO Socket

The 16-way IO expander socket is an external interface for specific customer applications that use Expansion Cards. The signals available from this interface socket are:

- 2 GPIOs
- 1 AUX-DAC
- 1 AUX-ADC
- 1 SPI1 (SPI1-IO, SPI1-I1, SPI1-CLIK, SPI1-CS)
- GPS Status Indicator Output

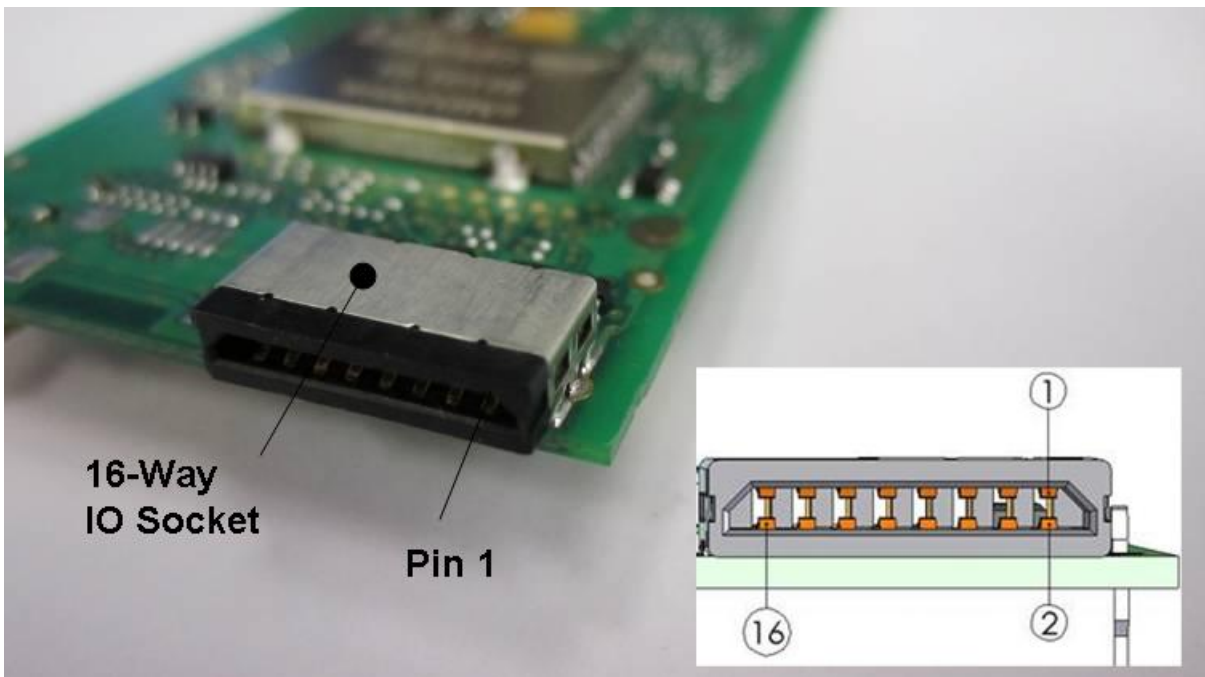

Figure 6. 16-way IO Expander Socket

The following table lists the pin description of the 16-pin IO expander socket. For recommendations on the expander socket, refer to section 10 Connector and Peripheral Devices References.

Table 1: 16-way IO Expander Socket Pin Description

Pin Number	Signal/Description	Pin Number	Signal/Description
1	Reserved	9	GPIO26
2	Reserved	10	AUX-DAC
3	Reserved	11	AUX-ADC
4	Reserved	12	SPI1-IO
5	Reserved	13	SPI1-I
6	GPS Status Indicator	14	SPI1-CLK
7	GPIO27	15	SPI1-CS
8	Reserved	16	GND

### 1.2.1.3. General Purpose Input/Output

The IO+GPS Expansion Card provides a total of 6 general purpose I/Os which are only available when the multiplexed counterparts aren't used. These GPIOs can be used to control any external devices such as GPS, Bluetooth, LCD or other customer external application.

Refer to the table below for the pin description of the general purpose IOs.

Table 2: GPIO Pin Description

Pin Number	Signal	I/O	I/O Type	Reset State	Multiplexed With
9	GPIO26	I/O	Open Drain	Z	SCL
7	GPIO27	I/O	Open Drain	Z	SDA
14	GPIO28	I/O	2V8	Z	SPI1-CLK
12	GPIO29	I/O	2V8	Z	SPI1-IO
13	GPIO30	I/O	2V8	Z	SP1-I
15	GPIO31	I/O	2V8	Z	~SPI1-CS

## 1.2.2. FXTE02: Ethernet Expansion Card

The Ethernet Expansion Card has one external connection. This 10-pin socket is used as the external interface for the RJ-45 Ethernet cable.

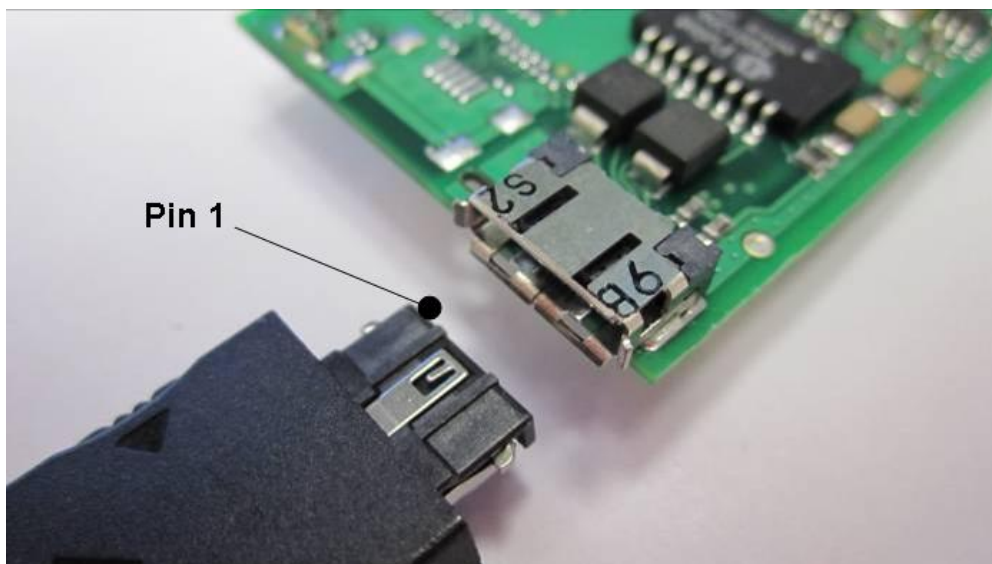

Figure 7. 10-pin Interface Socket

Refer to the following table for the pin description of the 10-pin interface socket.

Table 3: 10-pin Interface Socket Pin Description

Pin Number	Description
1	DGND
2	TX_D1-
3	TX_D1+
4	RX_D2-
5	RX_D2+
6	BI_D3+
7	BI_D3-
8	BI_D4+
9	BI_D4-
10	DGND

### 1.3. 50-pin Expansion Card Connector

Both FXTE01 and FXTE02 have a 50-pin expansion card connector. The high-density 50-pin Expansion Card Connector is used for interfacing the Expansion Card with the Fastrack Xtend motherboard.

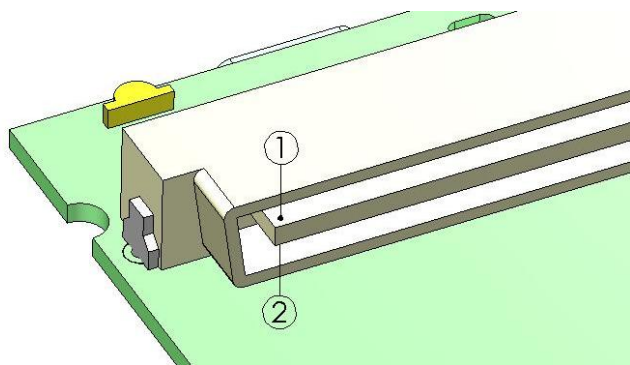

Figure 8. 50-pin Expansion Card Connector

The following table lists the pin description of the 50-pin expansion card connector. For recommendations on the 50-pin connector, refer to section 10 Connector and Peripheral Devices References.

Pin Number	Description	Pin Number	Description
1	GND	26	RTS2
2	GND	27	Reserved
3	Reserved	28	GPIO26
4	Reserved	29	GPIO19
5	Reserved	30	GPIO27
6	Reserved	31	GPIO20
7	NC	32	INT0/GPIO3
8	NC	33	GPIO23
9	NC	34	GPIO22
10	1.8V Digital supply from the embedded module	35	DTR1-CT108/2
11	2.8V Digital supply from the embedded module	36	PCM-SYNC
12	BOOT	37	PCM-IN
13	RESET	38	PCM-CLK
14	AUX-ADC	39	PCM-OUT
15	SPI1-CS	40	AUX-DAC
16	SPI1-CLK	41	2.8V supply from the Fastrack Xtend
17	SPI1-I	42	GND
18	SPI1-IO	43	DC-IN
19	SPI2-CLK	44	DC-IN
20	SPI2-IO	45	GND
21	SPI2-CS	46	4V supply from the Fastrack Xtend
22	SPI2-I	47	4V supply from the Fastrack Xtend
23	RXD2	48	GND
24	TXD2	49	GND
25	CTS2	50	GND

## 2. Expansion Card Basic Requirements

This section discusses the minimum requirements needed for the expansion card to function properly.

### 2.1. FXTE01 Requirements

For the IO+GPS expansion card to function properly, the following requirements must be met:

- The GPS feature must be activated on the Fastrack Xtend. (Consult your distributor for more information).
- Companion GPS (C-GPS) library must be loaded to the Fastrack Xtend. This can be found on the Sierra Wireless Software Suite 4.22 or later versions.
- The Sierra Wireless GPS application or a customer's own developed application must be running on the Fastrack Xtend.

### 2.2. FXTE02 Requirements

For the Ethernet expansion card to function properly, the following requirements must be met:

- Sierra Wireless Suite 2.x must be installed on the Fastrack Xtend. Consult your distributor for more information.
- The Sierra Wireless Ethernet application or a customer's own developed application must be running on the Fastrack Xtend.



### 3. Features and Services

This section enumerates the features and services available on both FXTE01 and FXTE02.

**Table 4: FXTE01 and FXTE02 Expansion Card Basic Features**

Features	FXTE01	FXTE02
<b>Sierra Wireless Software Suite</b>	Sierra Wireless Software Suite programmable: <ul style="list-style-type: none"> <li>• Native execution of embedded standard ANSI C applications</li> <li>• Custom AT command creation</li> <li>• Custom application library creation</li> <li>• Standalone operation</li> </ul>	Sierra Wireless Software Suite programmable: <ul style="list-style-type: none"> <li>• Native execution of embedded standard ANSI C applications</li> <li>• Custom AT command creation</li> <li>• Custom application library creation</li> <li>• Standalone operation</li> </ul>
<b>Interfaces</b>	<ul style="list-style-type: none"> <li>• AT command set based on V.25 or later and GSM 07.05 &amp; 07.07.</li> <li>• Interface for embedded application.</li> </ul>	<ul style="list-style-type: none"> <li>• AT command set based on V.25 or later and GSM 07.05 &amp; 07.07.</li> <li>• Interface for embedded application.</li> </ul>
<b>GPS Standard</b>	GPS L-Band (1575.42MHz) C/A Code	N/A
<b>LAN</b>	N/A	<ul style="list-style-type: none"> <li>• IEEE 802.3 Compatible</li> <li>• Integrated MAC and 10 BASE-T PHY</li> <li>• Receiver and collision squelch circuit</li> <li>• Supports one 10BASE-T port</li> <li>• Supports Full and Half-Duplex modes</li> <li>• Shielded RJ-45</li> </ul>



## 4. Technical Characteristics

### 4.1. Mechanical Characteristics

The following table lists the mechanical characteristics of the Expansion Card.

Table 5: Expansion Card Mechanical Characteristics

<b>PCB Dimension</b>	58mm x 35.7mm x 1mm (typical)
<b>Overall Dimension (including connectors)</b>	59.5 x 35.7 x 10.01mm (typical)
<b>Weight</b>	< 10 grams (typical)

### 4.2. Physical Dimensions

#### 4.2.1. FXTE01: IO+GPS Expansion Card

Refer to the figure below for the physical dimensions of the IO+GPS Expansion Card.



Figure 9. FXTE01 Physical Dimensions

## 4.2.2. FXTE02: Ethernet Expansion Card

Refer to the figure below for the physical dimensions of the Ethernet Expansion Card.

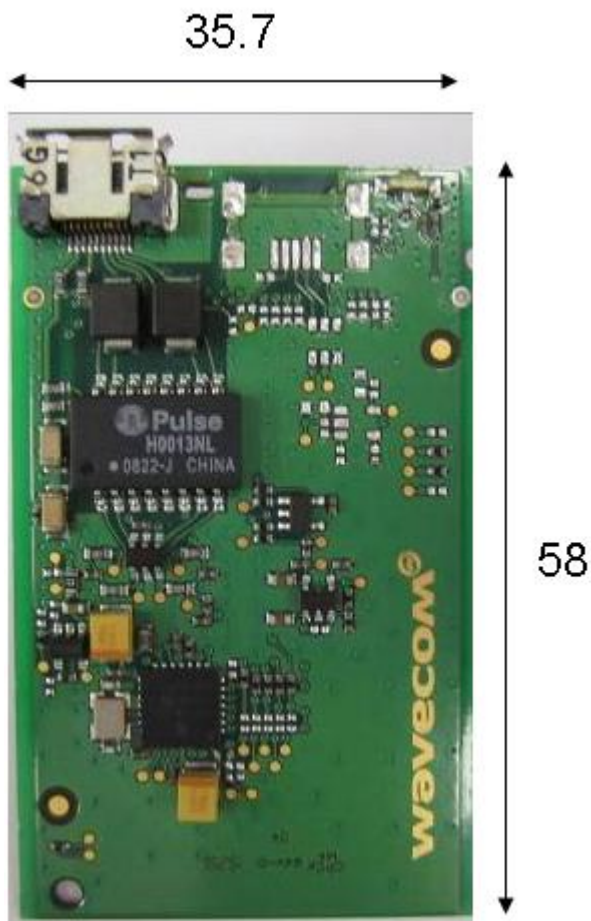

Figure 10. FXTE02 Physical Dimensions

## >> 5. Using the Expansion Card

### 5.1. Getting Started

#### 5.1.1. Installing the Expansion Card

To install either Expansion Card, follow the procedures listed below.

---

**Caution:** Remove the power from the Fastrack Xtend when installing the Expansion Card.

---

*Note:* Although figures used in this sub-section are based on the FXTE02, the same procedures apply to the FXTE01.

---

1. Unscrew the original backplate cover of the Fastrack Xtend.

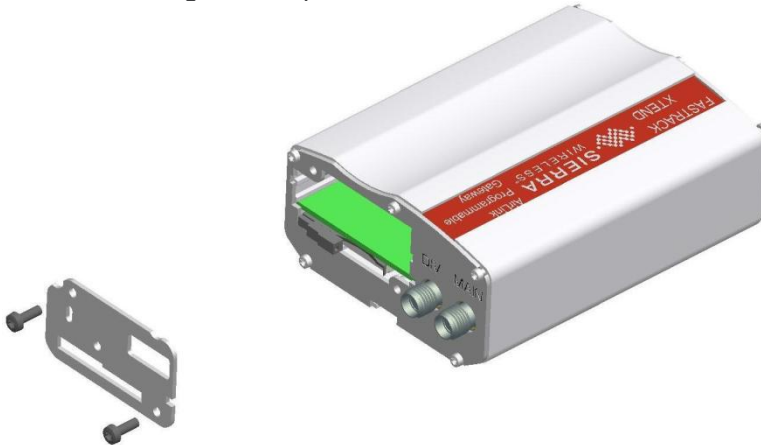

2. Align the Ethernet Expansion Card on the guide rail inside the Fastrack Xtend. Slide the board until the 50-pin expansion card connector mates with the Fastrack Xtend.

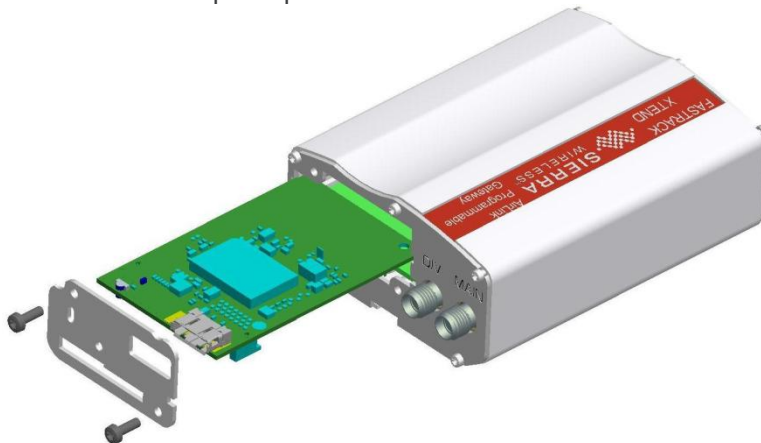

3. Replace the original backplate with the new Expansion Card backplate and screw it in place.



## 5.1.2. Expansion Card Quick Check

To check if the Expansion Card was properly installed in the Fastrack Xtend, perform the following test.

1. Connect a serial cable between the Fastrack Xtend and the PC COM port.
  - a. If using FXTE02, make sure to also connect the RJ45 Ethernet cable between the Fastrack Xtend and the PC.
2. Apply power on the Fastrack Xtend.
3. Open a communication software (for example, HyperTerminal); if the COM port isn't configured yet, configure it as follows:
  - a. Bits per second: 115200
  - b. Data bits: 8
  - c. Parity: None
  - d. Stop bits: 1
  - e. Flow control: None

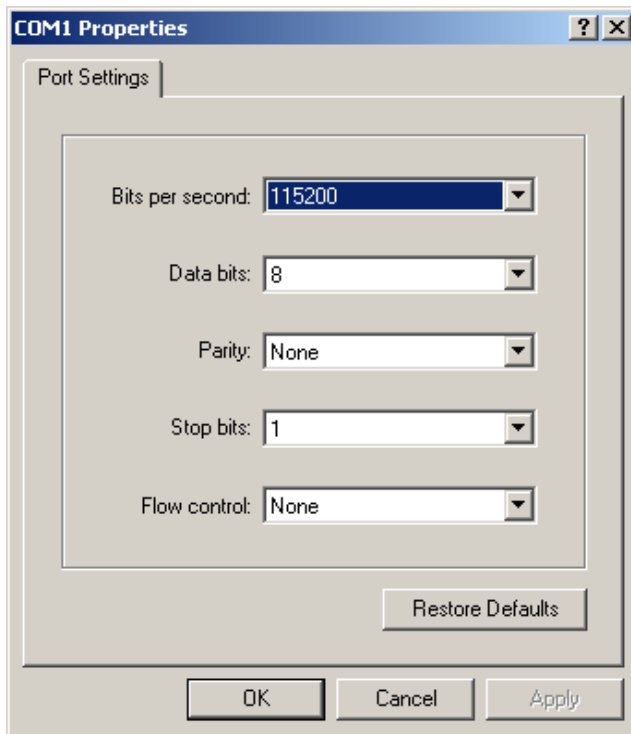

4. From the HyperTerminal window, enter:  
**AT↵**
5. When communications have been established, the Fastrack Xtend will respond with an "OK", which is displayed in the HyperTerminal window.

---

*Note:* For more information on basic AT Commands that may be used to check or establish communications with the Fastrack Xtend, refer to document [6] *Firmware 7.1b AT Commands Manual (for Sierra Wireless Software Suite 2.02a)*.

---

### 5.1.2.1. GPS Check (for FXTE01)

Ensure that the necessary GPS environment has been setup:

1. The GPS feature in the Fastrack Xtend has been activated
2. C-GPS library is loaded
3. The Sierra Wireless C-GPS sample code or customer application has been loaded in the Fastrack Xtend
4. The Fastrack Xtend is powered ON
5. Enter the following AT commands:
  - a. **AT+WOPEN=1** to activate the sample C-GPS code
  - b. **AT+NMEA=1** to specify that NMEA frames be sent in standard format
  - c. **AT+CGPS=2** to specify that UART2 is used by the GPS module
  - d. **AT+CONFIG=1** to save the configuration

If the procedures listed above are followed carefully, the Fastrack Xtend will start sending NMEA frames to the PC COM port.

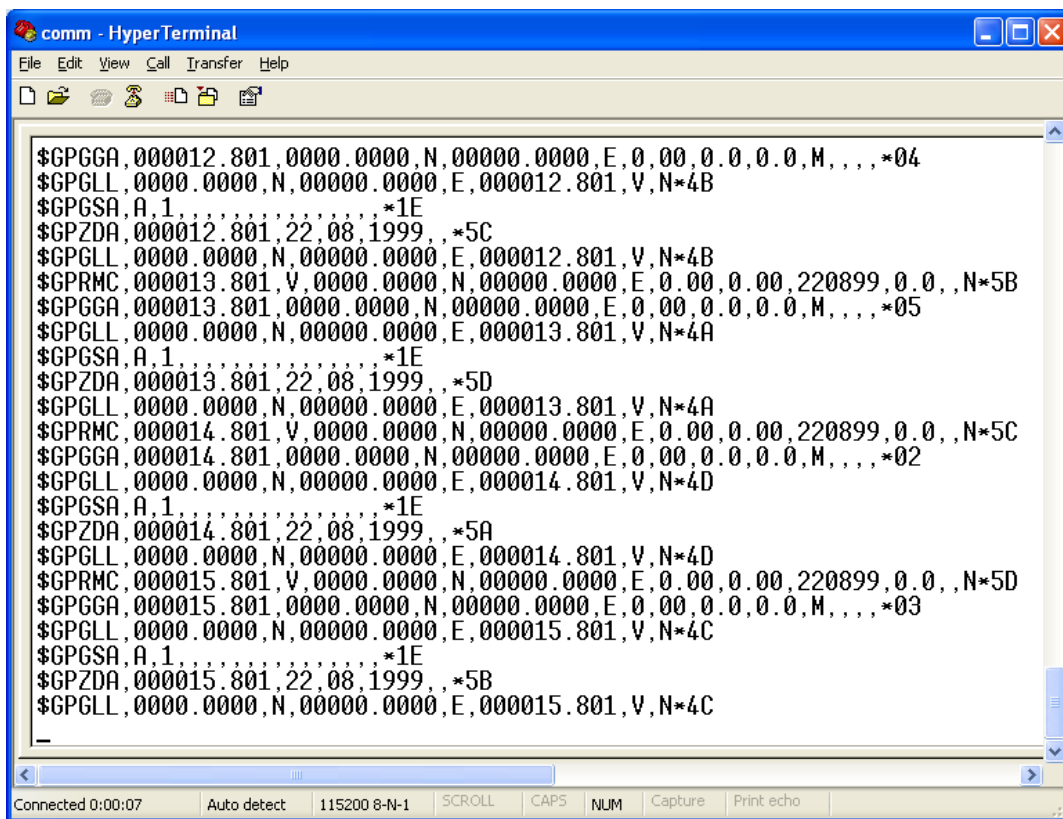

Figure 11. FXTE01 Running on Sierra Wireless Sample C-GPS Code

The GPS active antenna power supply is disabled by default. This can be activated with the following AT commands.

Table 6: Enabling the Active Antenna Power Supply

AT Command	Response	Description
AT+WHCNF=0,0	OK	Deactivates the Keypad feature of the Fastrack Xtend.
AT+WIOM=1,"GPIO8",1,0	OK	Activates GPIO8 as an output and sets the initial state to LOW.
AT+WIOW="GPIO8",0	OK	Sets GPIO8 to LOW and enables the 3.3V supply output.

Note that once the power is removed from the Fastrack Xtend at the next power ON, the GPS active antenna supply will automatically be activated if the C-GPS is also running.

If C-GPS is turned OFF, the active antenna power supply will also be turned OFF.

Table 7: Turning the Active Antenna Power Supply ON/OFF

AT Command	Response	Description
AT+WIOW="GPIO8",1	OK	Sets GPIO8 to HIGH and disables the 3.3V supply output.
AT+WIOW="GPIO8",0	OK	Sets GPIO8 to LOW and enables the 3.3V supply output.

If **AT+WIOM=1,"GPIO8",1,0** is entered initially, the initial state of GPIO8 will always be LOW at the next power ON regardless of the GPIO status before power OFF.

### 5.1.2.2. Ethernet Check (for FXTE02)

Ensure that the necessary Ethernet environment has been setup:

1. The Sierra Wireless Ethernet sample code or customer application has been loaded in the Fastrack Xtend
2. The LAN cable is connected to the Ethernet RJ45 Ethernet cable
3. The Fastrack Xtend is powered ON

Note that when using the Ethernet sample code provided by Sierra Wireless, a normally operating Ethernet Expansion Card will display the acquired IP address.

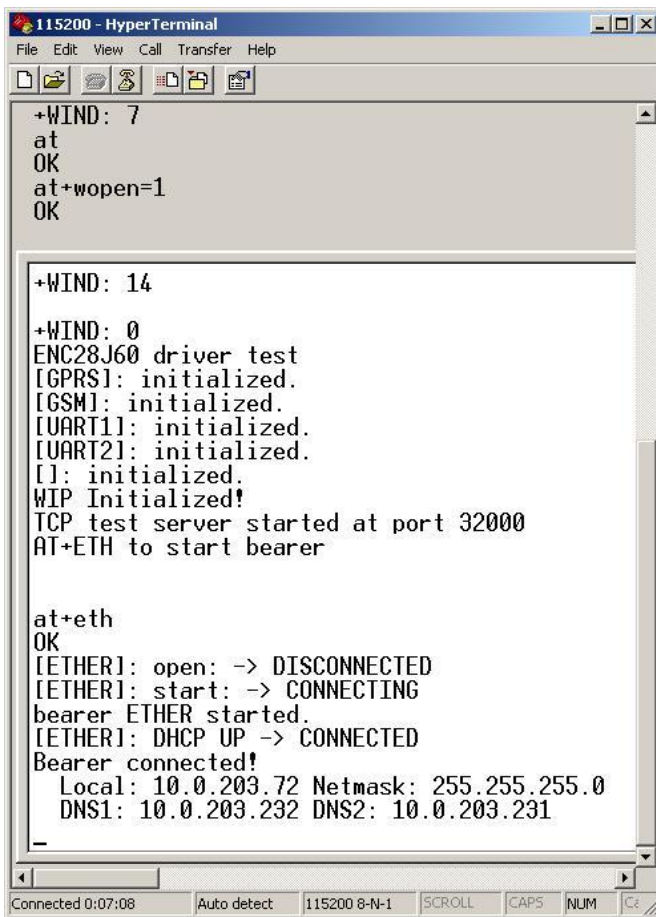

Figure 12. FXTE02 Running on Sierra Wireless Sample Ethernet Code

The following tables enumerate the various AT Commands that may be used with the Ethernet Expansion Card.

Table 8: Activating the Sierra Wireless Ethernet Sample Code

AT Command	Response	Description
AT+WOPEN=1	OK	Activates the Sierra Wireless Ethernet sample code.

**Table 9: Activating or Deactivating the Ethernet Board**

AT Command	Response	Description
AT+ETH=1	OK	Turns ON Ethernet (default)
AT+ETH=0	OK	Turns OFF Ethernet

**Table 10: Setting the DHCP Address**

AT Command	Response	Description
AT+IPCONFIG=1	OK	Sets to DHCP (Reset is required for this command to take effect.)
AT+IPCONFIG?	+IPCONFIG: 1,0	IP is set to DHCP
AT+IPCONFIG?	+IPCONFIG: 0,1,"192.168.0.1"	IP is set to static IP 192.168.0.1

**Table 11: Setting the Static IP Address**

AT Command	Response	Description
AT+IPCONFIG=0,192,168,0,1	OK	Sets the static IP address where: <ul style="list-style-type: none"> <li>• 0 = set to static IP</li> <li>• 192,168,0,1 = IP address</li> </ul> (Reset is required for this command to take effect.)
AT+IPCONFIG?	+IPCONFIG: 0,1, "192.168.0.1"	Interrogates the static IP
AT+IPCONFIG?	+IPCONFIG: 1,0	IP is set to DHCP

**Table 12: Setting the DNS IP Address for Static IP Option**

AT Command	Response	Description
AT+IPDNS=192,168,1,2	OK	Sets the static IP address where: <ul style="list-style-type: none"> <li>• 192,168,1,2 = IP DNS address</li> </ul>
AT+IPDNS?	+IPDNS: 1, "192.168.1.2"	Interrogates the DNS IP
AT+IPDNS?	+IPDNS: 0	"0" means DHCP is enabled

**Table 13: Setting the Gateway IP Address for Static IP Option**

AT Command	Response	Description
AT+IPGW=192,168,1,1	OK	Sets the static IP address where: <ul style="list-style-type: none"> <li>• 192,168,1,1 = Gateway IP address</li> </ul>
AT+IPGW?	+IPGW: 1, "192.168.1.1"	Interrogates the Gateway IP
AT+IPGW?	+IPGW: 0	"0" means DHCP is enabled

**Table 14: Setting the Netmask IP Address for Static IP Option**

AT Command	Response	Description
AT+IPNETMASK=255,255,255,0	OK	Sets the static IP address where: <ul style="list-style-type: none"> <li>• 255,225,255,0 = Netmask IP address</li> </ul>

AT Command	Response	Description
AT+IPNETMASK?	+IPNETMASK: 1, "255.255.255.0"	Interrogates the Netmask IP
AT+IPNETMASK?	+IPNETMASK: 0	"0" means DHCP is enabled

## 5.2. Expansion Card Operational Status

### 5.2.1. FXTE01: IO+GPS Expansion Card

The IO+GPS Expansion Card operation status could be interpreted by the green LED located near the GPS RF connector.

The following table describes the operational status of FXTE01.

Table 15: FXTE01 Operational Status

LED Status	FXTE01 Status
ON	GPS fix has not been achieved.
ON – Blinking	GPS fix has been achieved.
OFF	The Fastrack Xtend is switched OFF or the GPS feature is not activated.

### 5.2.2. FXTE02: Ethernet Expansion Card

The Ethernet Expansion Card operational status could be interpreted by the green and yellow LED located in front of the Ethernet Expansion Card PCB.

The following table describes the operational status of the FXTE02.

Table 16: FXTE02 Operational Status

LED Description	LED Status	FXTE02 Status
Link LED (Green)	ON	The Ethernet is in synch with the LAN/router.
	OFF	The Ethernet is not in synch with the LAN/router; or Open AT <sup>®</sup> is not running.
Activity LED (Yellow)	ON – Blinking	The Ethernet is linked to the network.
	OFF	The Ethernet is not in synch with the LAN/router; or Open AT <sup>®</sup> is not running.



## 6. Troubleshooting the Expansion Card

This section describes the possible problems that might be encountered when using the Expansion Card and their corresponding solutions.

To read about other troubleshooting information, refer to the Knowledge Base page at <http://www.sierrawireless.com/en/Support/knowledgebase.aspx>.

### 6.1. No Communications with the Expansion Card through the Serial Link

If the Expansion Card does not respond to AT commands through the serial link, refer to the table below for possible causes and their corresponding solutions.

Table 17: No Communications with the Expansion Card Through the Serial Link

If the Expansion Card returns	Then ask	Action
Nothing	Is the Fastrack Xtend powered correctly?	Make sure that the external power supply is connected to the Fastrack Xtend and provides a voltage within the range of 4.75V to 32V.
	Is the Expansion Card powered properly?	Make sure that the Expansion Card is properly plugged in to the Fastrack Xtend.
	Is the serial cable connected at both sides?	Check the serial cable connection.
	Does the serial cable correctly follow the pin assignments? Refer to document [8] AirLink FXT Series User Guide for more information about the serial cable pin assignments.	Connect the cable by following the pin assignments as given in document [8] AirLink FXT Series User Guide.
Nothing or non-significant characters	Is the communication program properly configured on the PC?	Ensure that the settings of the communication program are compatible with the settings of the Fastrack Xtend.  The Fastrack Xtend factory settings are: <ul style="list-style-type: none"><li>• Data bits = 8</li><li>• Parity = none</li><li>• Stop bits = 1</li><li>• Baud = 115200 bps</li><li>• Flow control = hardware</li></ul>
	Is there another program interfering with the communication program (i.e. conflict on communication port access)?	Close the interfering program.

If using FXTE01, refer to the following table for other possible problems and their corresponding solution.

**Table 18: No Communications with FXTE01 Through the Serial Link**

<b>If the Expansion Card returns</b>	<b>Then ask</b>	<b>Action</b>
GPS not sending data/no NMEA	Has the Sierra Wireless C-GPS sample code or customer application been loaded and running on the Fastrack Xtend?	Run the Sierra Wireless C-GPS sample code or the customer application.

If using FXTE02, refer to the following table for other possible problems and their corresponding solution.

**Table 19: No Communications with FXTE02 Through the Serial Link**

<b>If the Expansion Card returns</b>	<b>Then ask</b>	<b>Action</b>
Nothing	If using FXTE02, is the RJ45 Ethernet cable properly connected at both sides?	Check the RJ45 Ethernet cable connection.

## 7. Functional Description

The Expansion Card is interfaced to the Fastrack Xtend motherboard through the 50-pin expansion card connector. All the DC supplies are applied through this connector so no external supply is necessary.

### 7.1. FXTE01: IO+GPS Expansion Card

With the Sierra Wireless Software Suite running, the Fastrack Xtend motherboard communicates with the IO+GPS Expansion Card through UART2. The GPS module communicates on UART2 with the following configuration:

- Baud rate: 57600bps
- Character framing: 8 Data bits
- Parity: 1 stop bit and Odd parity
- Flow control: no flow control

The Sierra Wireless Software Suite controls the following:

- Enables/disables the internal LDOs of the IO+GPS expansion card to power-up the GPS
- Enables/disables the RF block of the GPS
- Enables a trigger to reset the GPS module
- Enables/disabled the GPS status indicator output which is connected to an LED driver
- Enables/disables the GPS antenna bias voltage at 3.3V

#### 7.1.1. Architecture

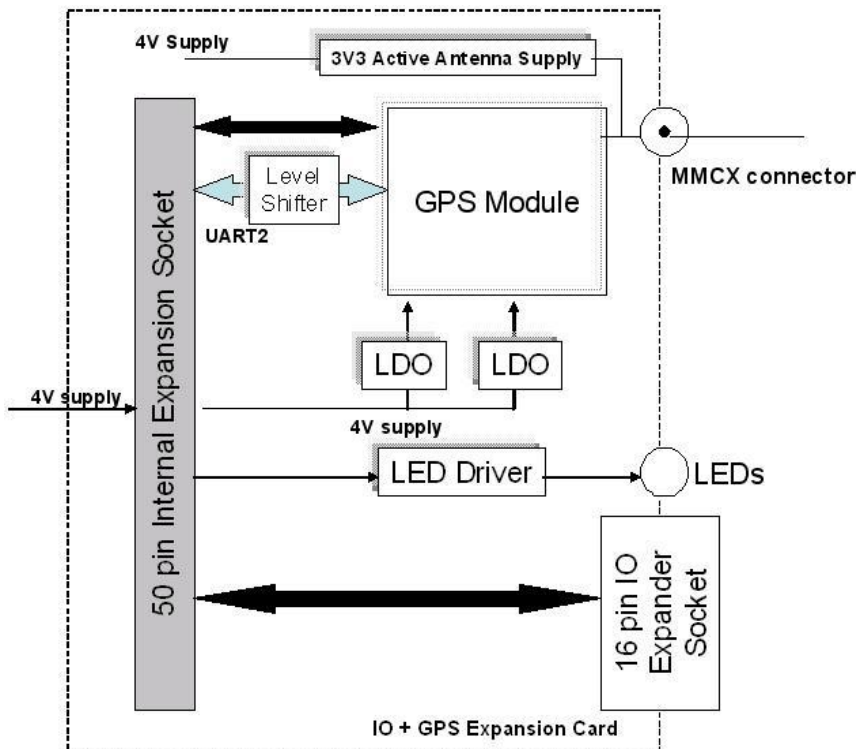

Figure 13. FXTE01 Architecture

## 7.2. FXTE02: Ethernet Expansion Card

With the Sierra Wireless Software Suite running, the Fastrack Xtend motherboard communicates with the Ethernet Expansion Card through SPI2.

The Sierra Wireless Software Suite controls the following:

- Data flow on the SPI2 bus between the Ethernet controller and the Fastrack Xtend.
- Enables/disables the internal LDOs of the Ethernet controller and EEPROM chip.
- Data access to the EEPROM through I2C.

### 7.2.1. Architecture

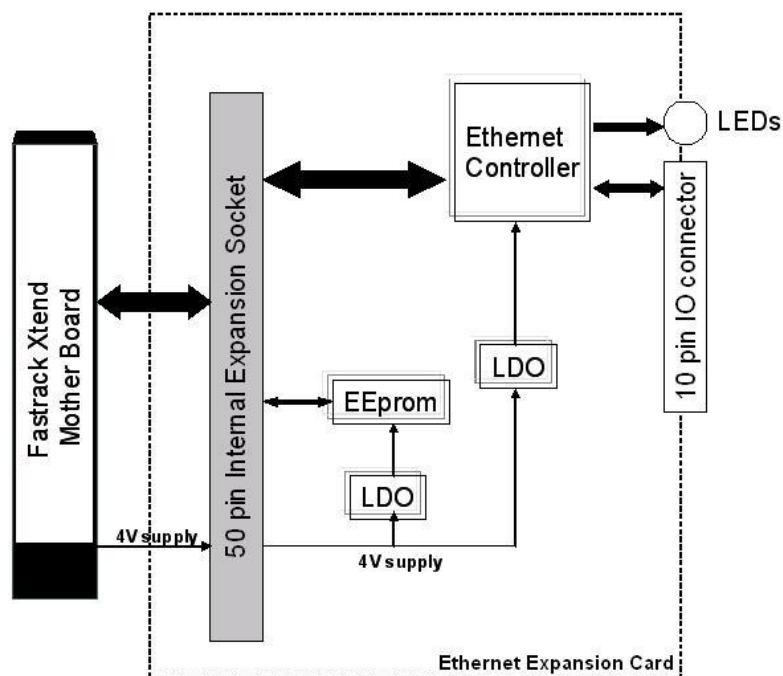

Figure 14. FXTE02 Architecture

## 7.3. Electrical Characteristics

### 7.3.1.1. Power Supply

Both FXTE01 and FXTE02 expansion cards have the same operating voltage.

Table 20: Electrical Characteristics

<b>Operating Voltage</b>	4V DC
--------------------------	-------

*Note: The Expansion Card is powered once the enable pins are activated by the Sierra Wireless Software Suite.*

The table below describes the power consumption at the Expansion Card interface based on operating conditions.

**Table 21: Ethernet Expansion Card Power Consumption**

Expansion Card	Mode	Typical Value*	Unit
FXTE01	Powered ON	150	mA
FXTE02	GPS Powered ON	96	mA

\* The power consumption indicated does not include active antenna consumption.

## 7.4. Extra Current Consumption from the DC-IN Source

Depending on various DC-IN voltages of the Fastrack Xtend, the extra current consumption drawn by the Expansion Card will also vary. The following table describes the current consumption at the Expansion Card interface based on operating conditions.

**Table 22: Extra Current Consumption from DC-IN Source for the FXTE01 (Typical Values)**

Condition		Extra Current Consumption for Additional Feature (mA)		
Fastrack Xtend Mode	GPS Feature	@4.75VDC	@13.2VDC	@32VDC
Connected	GPS Enabled with GPS antenna bias ON	137	42	22
Non-Connected	GPS Enabled with GPS antenna bias ON	134	46.3	22.6
	GPS Enabled with GPS antenna bias OFF	111	37.8	18.7
	GPS antenna bias ON	27	8.5	3.8

**Table 23: Extra Current Consumption from DC-IN Source for the FXTE02 (Typical Values)**

Condition		Extra Current Consumption for Additional Feature (mA)		
Fastrack Xtend Mode	Ethernet Feature	@4.75VDC	@13.2VDC	@32VDC
Connected	Enabled Idle	163mA	53.7mA	20.8mA
Non-Connected	Enabled Idle	171.7mA	49.6mA	24.0mA
	On Communication	185mA	52.9mA	24.2mA

## 7.5. Other Specifications

### 7.5.1. FXTE01: IO+GPS Expansion Card

#### 7.5.1.1. GPS Receiver Frequency

Table 24: GPS Receiver Frequency

Characteristics	GPS
Frequency RX	1575.42 MHz

#### 7.5.1.2. GPS RF Performance

The GPS performance for the receiver is given in the table below.

Table 25: FXTE01 Receiver Performances

Sierra Wireless Software Suite 4.11	Conditions	Notes	Value	Remarks
Accuracy	-130 dBm (outdoor) In dynamic mode	50% percentile	3.7 m CEP	
	-130 dBm (outdoor) In dynamic mode	95% percentile	6.8 m CEP	
	-140 dBm In dynamic mode	50% percentile	6.1 m CEP	
	-145 dBm In dynamic mode	50% percentile	13.9 m CEP	
Velocity Accuracy	Static mode	First fix only	0.1 m/s	Typical
	Static mode	Continuous fixes	0 m/s	Typical
TTFF Hot Start	-	Mean	3.5 s	Typical
TTFF Warm Start	-	Mean	30s	Typical
TTFF Cold Start	Clear Sky conditions	Mean	38 s	Typical
	Clear Sky conditions	95% percentile	45 s	Typical
Update Rate	-130 dBm	Continuous fixes	1 Hz	Typical

#### 7.5.1.3. External Antenna

The external antenna is connected to the IO+GPS Expansion Card's GPS via the MMCX connector. The external antenna must fulfill the characteristics listed in the table below.

Table 26: FXTE01 External Antenna Characteristics

Characteristic	Value
Antenna Frequency Range	1.57542GHz $\pm$ 1.023MHz (L1-Band)
Impedance	50 $\Omega$ nominal
Voltage Supply	3.3V $\pm$ 0.5VDC
Gain (antenna + cable)	2dBi

## 7.5.2. FXTE02: Ethernet Expansion Card

### 7.5.2.1. RJ45 Ethernet Interface Socket

The RJ45 Ethernet interface socket is a standard 10BASE-T interface that complies with IEEE 802.3 specifications. Refer to the table below for the RJ45 interface cable pin description.

Table 27: RJ45 Pin Description

RJ45 Socket Pin Number	Signal	I/O	Description
1	TD+	O	Differential data transmit positive
2	TD-	O	Differential data transmit negative
3	RD+	I	Differential data receive positive
4	Not used by 10BASE-T	-	
5	Not used by 10BASE-T	-	
6	RD-	I	Differential data receive positive
7	Not used by 10BASE-T		
8	Not used by 10BASE-T		
9			
10			



# 8. Reliability Standards: Compliance and Recommendations

## 8.1. Reliability Compliance

The Expansion Card is compliant with the following requirements.

Table 28: Standards Conformity for Expansion Cards

Abbreviation	Definition
IEC	International Electro technical Commission
ISO	International Organization for Standardization

## 8.2. Applicable Standards Listing

The table hereafter gives the basic list of standards applicable to the Expansion Card.

*Note: References to any features can be found from these standards.*

Table 29: Applicable Standards and Requirements for Expansion Cards

Document	Current Version	Title
IEC6006826	7.0	Environmental testing - Part 2.6: Test FC: Sinusoidal Vibration.
IEC60068234	73	Basic environmental testing procedures part 2: Test FD: random vibration wide band - general requirements. Cancelled and replaced by <b>IEC60068-2-64</b> . For reference only.
IEC60068264	2.0	Environmental testing - part 2-64: Test FH: vibration, broadband random and guidance.
IEC60068232	2.0	Basic environmental testing procedures - part 2: Test ED: (procedure 1) Withdrawn & replaced by <b>IEC60068-2-31</b> . For reference only.
IEC60068231	2.0	Environmental testing part 2-31: Test EC: rough handling shocks, primarily for equipment-type specimens.
IEC60068229	2.0	Basic environmental testing procedures - part 2: Test EB and guidance: bump. Withdrawn and replaced by <b>IEC60068-2-27</b> . For reference only.
IEC60068227	4.0	Environmental testing - part 2-27: Test EA and guidance: shock.
IEC60068214	6.0	Environmental testing - part 2-14: Test N: change of temperature.
IEC6006822	5.0	Environmental testing - part 2-2: Test B: dry heat.
IEC6006821	6.0	Environmental testing - part 2-1: Test A: cold.
IEC60068230	3.0	Environmental testing - part 2-30: Test DB: damp heat, cyclic (12 h + 12 h cycle).
IEC6006823	69 w/A1	Basic environmental testing procedures part 2: Test CA: damp heat, steady State. Withdrawn and replaced by <b>IEC60068-2-78</b> . For reference only.
IEC60068278	1.0	Environmental testing part 2-78: Test CAB: damp heat, steady state.

Document	Current Version	Title
IEC60068238	2.0	Environmental testing - part 2-38: Test Z/AD: composite temperature/humidity cyclic test.
IEC60068240	1.0 w/A1	Basic environmental testing procedures - part 2: Test Z/AM combined cold/low air pressure tests.
ISO167501	2ND	Road vehicles - environmental conditions and testing for electrical and electronic equipment - part 1: general.
ISO167502	2ND	Road vehicles - environmental conditions and testing for electrical and electronic equipment - part 2: electrical loads.
ISO167503	2ND	Road vehicles - environmental conditions and testing for electrical and electronic equipment - part 3: mechanical loads.
ISO167504	2ND	Road vehicles - environmental conditions and testing for electrical and electronic equipment - part 4: climatic loads.
IEC60529	2.1 w/COR2	Degrees of protection provided by enclosures (IP code).
IEC60068217	4.0	Basic environmental testing procedures - part 2: Test Q: sealing.
IEC60068218	2.0	Environmental testing - part 2-18: Tests - R and guidance: water.
IEC60068270	1.0	Environmental testing - part 2: tests - test XB: abrasion of markings and letterings caused by rubbing of fingers and hands.
IEC60068268	1.0	Environmental testing - part 2: tests - test I: dust and sand.
IEC60068211	3.0	Basic environmental testing procedures, part 2: test KA: salt mist.
IEC60068260	2.0	Environmental testing - part 2: Test KE: flowing mixed gas corrosion test.
IEC60068252	2.0 w/COR	Environmental testing - part 2: Test KB: salt mist, cyclic (sodium chloride solution).

## 8.3. Environmental Specifications

The FXTE01 and FXTE02 Expansion Cards are compliant with the operating classes listed below. The ideal temperature range of the environment for each operating class is also specified.

Table 30: Operating Class Temperature Range

Conditions	FXTE01 Temperature Range	FXTE02 Temperature Range
Operating / Class A	-20°C to +55°C	0°C to +55°C
Operating / Class B*	-30°C to +65°C	0°C to +65°C
Storage	-40°C to +85°C	-40 °C to +85°C

### 8.3.1. Function Status Classification

The classes reported below comply with the Annex “ISO Failure Mode Severity Classification”, ISO Standard 7637, and Section 1.

*Note: The word “function” used here only concerns the function performed by the Expansion Card.*

Table 31: ISO Failure Mode Severity Classification

Class	Definition
CLASS A	<p>All equipment/system functions are fulfilled normally (100% functional) during and after the constraint.</p> <p>The Expansion Card shall exhibit normal function during and after environmental exposure. The Expansion Card performance shall meet the minimum requirements of 3GPP or appropriate wireless standards.</p>
CLASS B	<p>All equipment/system functions are fulfilled normally during application of the constraint; however, one or several of them may be out of the specified tolerances. After application of the constraint, all functions automatically return within standard limits. The memories shall remain in compliance with Class A.</p> <p>The Expansion Card shall exhibit the possibility at all times to establish a voice, SMS or DATA call. Unless otherwise stated, full performance should return to normal after the external influence has been removed.</p>

### 8.3.2. Reliability Prediction Model

The following tables enumerate the different tests performed on both FXTE01 and FXTE02 Expansion Cards and their corresponding conditions and results.

#### 8.3.2.1. FXTE01 (IO+GPS Expansion Card)

##### 8.3.2.1.1. Life Stress Test

The following tests the FXTE01’s product performance.

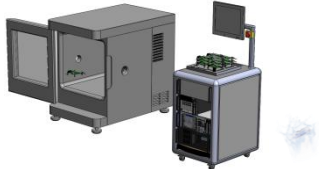

Table 32: Life Stress Test

Designation	Condition
<p><b>Performance Test PT3T° &amp; PT</b></p> 	Standard: N/A
	<p>Special conditions:</p> <ul style="list-style-type: none"> <li>• Temperature:                             <ul style="list-style-type: none"> <li>▪ Class A: -20°C to +55°C</li> <li>▪ Class B: -30°C to +65°C</li> </ul> </li> <li>• Rate of temperature change: ± 3°C/min</li> <li>• Recovery time: 3 hours</li> </ul>
	Operating conditions: Powered
	Duration: 14 days

### 8.3.2.1.2. Environmental Resistance Stress Tests

The following tests the FXTE01’s resistance to extreme temperature.

Table 33: Environmental Resistance Stress Tests

Designation	Condition
<b>Cold Test</b> <b>COT</b> 	Standard: IEC 680068-2-1, Test Ab
	Special conditions: <ul style="list-style-type: none"> <li>• Temperature: -40°C</li> <li>• Rate of temperature change: <math>dT/dt \geq \pm 3^\circ\text{C}/\text{min}</math></li> <li>• Recovery time: 3 hours</li> </ul>
	Operating conditions: Un-powered
	Duration: 72 hours
<b>Resistance to Heat Test</b> <b>RH</b> 	Standard: IEC 680068-2-2, Test Bb
	Special conditions: <ul style="list-style-type: none"> <li>• Temperature: +85°C</li> <li>• Rate of temperature change: <math>dT/dt \geq \pm 3^\circ\text{C}/\text{min}</math></li> <li>• Recovery time: 3 hours</li> </ul>
	Operating conditions: The DUT is switched ON for 1 minute and then OFF for 1 minute
	Duration: 60 days
<b>Dry Heat Test</b> <b>DHT</b> 	Standard: IEC 680068-2-2, Test Bb
	Special conditions: <ul style="list-style-type: none"> <li>• Temperature: +85°C</li> <li>• Rate of temperature change: <math>dT/dt \geq \pm 3^\circ\text{C}/\text{min}</math></li> <li>• Recovery time: 3 hours</li> </ul>
	Operating conditions: Un-powered
	Duration: 72 hours

### 8.3.2.1.3. Corrosive Resistance Stress Test

The following tests the FXTE01’s resistance to corrosive atmosphere.

Table 34: Corrosive Resistance Stress Test

Designation	Condition
<b>Humidity Test</b> <b>HT</b>	Standard: IEC 60068-2-3
	Special conditions: <ul style="list-style-type: none"> <li>• Temperature: +40°C</li> <li>• RH: 95%</li> <li>• Rate of temperature change: <math>dT/dt \geq \pm 3^\circ\text{C}/\text{min}</math></li> <li>• Recovery time: 3 hours</li> </ul>
	Operating conditions: The DUT is switched ON for 5 minutes and then OFF for 15 minutes

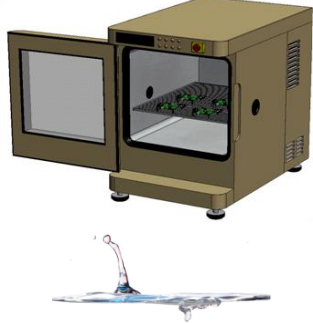
Designation	Condition
	Duration: 15 days

### 8.3.2.1.4. Thermal Resistance Cycle Stress Test

The following tests the FXTE01’s resistance to extreme temperature cycling.

Table 35: Thermal Resistance Cycle Stress Test

Designation	Condition
Thermal Shock Test TSKT 	Standard: IEC 60068-2-14 Special conditions: <ul style="list-style-type: none"> <li>• Upper temperature: +85°C</li> <li>• Lower temperature: -40°C</li> <li>• Rate of temperature change: 30s</li> <li>• Number of cycles: 200</li> <li>• Duration of exposure: 30 minutes</li> <li>• Recovery time: 3 hours</li> </ul> Operating conditions: Un-powered Duration: 72 hours

### 8.3.2.1.5. Mechanical Resistance Stress Tests

The following tests the FXTE01’s resistance to vibrations and mechanical shocks.

Table 36: Mechanical Resistance Stress Tests

Designation	Condition
	Standard: IEC 60068-2-6, Test Fc

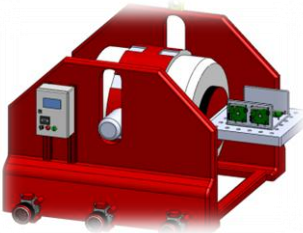
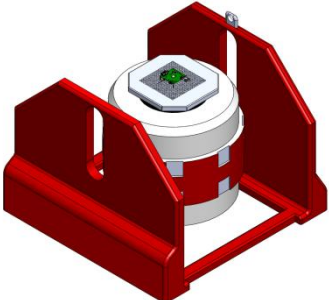
Designation	Condition
<p><b>Sinusoidal Vibration Test SVT</b></p> 	<p>Special conditions:</p> <ul style="list-style-type: none"> <li>• Frequency range: 10Hz to 1000Hz                             <ul style="list-style-type: none"> <li>▪ Displacement: ±5mm (peak)</li> </ul> </li> <li>• Frequency range: 16Hz to 62Hz                             <ul style="list-style-type: none"> <li>▪ Acceleration: 5G</li> </ul> </li> <li>• Frequency range: 62Hz to 200Hz                             <ul style="list-style-type: none"> <li>▪ Acceleration: 3G</li> </ul> </li> <li>• Frequency range: 200Hz to 1000Hz                             <ul style="list-style-type: none"> <li>▪ Acceleration: 1G</li> </ul> </li> <li>• Sweep rate: 1 oct/min.</li> <li>• Test duration: 20 cycles</li> <li>• Sweep directions: X, Y and Z</li> </ul> <p>Operating conditions: Un-powered</p> <p>Duration: 72 hours</p>
<p><b>Random Vibration Test RVT</b></p> 	<p>Standard: IEC 60068-2-64</p> <p>Special conditions:</p> <ul style="list-style-type: none"> <li>• Density spectrum: 0.96m<sup>2</sup>/s<sup>3</sup></li> <li>• Frequency range:                             <ul style="list-style-type: none"> <li>▪ 0.1 g<sup>2</sup>/Hz at 10Hz</li> <li>▪ 0.01 g<sup>2</sup>/Hz at 250Hz</li> <li>▪ 0.0005 g<sup>2</sup>/Hz at 1000Hz</li> <li>▪ 0.0005 g<sup>2</sup>/Hz at 2000Hz</li> </ul> </li> <li>• Slope: -3dB/octave</li> <li>• Acceleration: 0.9gRMS</li> <li>• Number of axis: 3</li> </ul> <p>Operating conditions: Un-powered</p> <p>Duration: 16 hours</p>
<p><b>Mechanical Shock Test MST</b></p> 	<p>Standard: IEC 60068-2-27, Test Ea</p> <p>Special conditions:</p> <ul style="list-style-type: none"> <li>• Wave form: Half sine</li> <li>• Peak acceleration: 50G</li> <li>• Duration: 11ms</li> <li>• Number of shocks: 3 per direction</li> <li>• Number of directions: 6 (±X, ±Y, ±Z)</li> </ul> <p>Operating conditions: Un-powered</p> <p>Duration: 12 hours</p>

### 8.3.2.1.6. Handling Resistance Stress Tests

The following tests the FXTE01’s resistance to handling malfunctions and damage.

Table 37: Handling Resistance Stress Tests

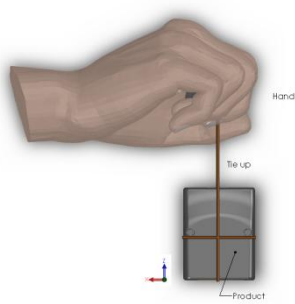
Designation	Condition
<b>ESD Test</b> 	Standard: IEC 1000-4-2
	Special conditions: <ul style="list-style-type: none"> <li>• Contact discharges: 10 positive and 10 negative applied</li> <li>• Voltage: <math>\pm 1\text{kV}</math>, <math>\pm 2\text{kV}</math></li> </ul>
	Operating conditions: Powered
	Duration: 12 hours
<b>Operational Durability OD</b>	Standard: N/A
	Special conditions: <ul style="list-style-type: none"> <li>• SIM Connector:                             <ul style="list-style-type: none"> <li>▪ Cycles: 40</li> <li>▪ Repetition Rate: 3s per cycle</li> <li>▪ Objective: Mating and de-mating</li> </ul> </li> <li>• System Connector:                             <ul style="list-style-type: none"> <li>▪ Cycles: 40</li> <li>▪ Repetition Rate: 3s per cycle</li> <li>▪ Objective: Mating and de-mating</li> </ul> </li> <li>• RF Connector:                             <ul style="list-style-type: none"> <li>▪ Cycles: 20</li> <li>▪ Repetition Rate: 5s per cycle</li> <li>▪ Objective: Mating and de-mating</li> </ul> </li> </ul>
	Operating conditions: Un-powered
	Duration: 24 hours
<b>Free Fall Test FFT</b> 	Standard : IEC 60068-2-32, Test Ed
	Special conditions: <ul style="list-style-type: none"> <li>• Drop: 2 samples for each direction</li> <li>• Equivalent drop height: 1m</li> <li>• Number of directions: 6 (<math>\pm X</math>, <math>\pm Y</math>, <math>\pm Z</math>)</li> <li>• Number of drops/face: 2</li> </ul>
	Operating conditions: Un-powered
	Duration: 24 hours

### 8.3.2.2. FXTE02 (Ethernet Expansion Card)

#### 8.3.2.2.1. Life Stress Test

The following tests the FXTE02's product performance.



Table 38: Life Stress Test

Designation	Condition
<b>Performance Test PT3T° &amp; PT</b>  	Standard: N/A
	Special conditions: <ul style="list-style-type: none"> <li>• Temperature:                             <ul style="list-style-type: none"> <li>▪ Class A: 0°C to +55°C</li> <li>▪ Class B: 0°C to +65°C</li> </ul> </li> <li>• Rate of temperature change: ± 3°C/min</li> <li>• Recovery time: 3 hours</li> </ul>
	Operating conditions: Powered
	Duration: 14 days

#### 8.3.2.2.2. Environmental Resistance Stress Tests

The following tests the FXTE02's resistance to extreme temperature.

Table 39: Environmental Resistance Stress Tests

Designation	Condition
<b>Cold Test COT</b>  	Standard: IEC 680068-2-1, Test Ab
	Special conditions: <ul style="list-style-type: none"> <li>• Temperature: -40°C</li> <li>• Rate of temperature change: dT/dt &gt;= ± 3°C/min</li> <li>• Recovery time: 3 hours</li> </ul>
	Operating conditions: Un-powered
<b>Resistance to Heat Test RH</b>  	Standard: IEC 680068-2-2, Test Bb
	Special conditions: <ul style="list-style-type: none"> <li>• Temperature: +85°C</li> <li>• Rate of temperature change: dT/dt &gt;= ± 3°C/min</li> <li>• Recovery time: 3 hours</li> </ul>
	Operating conditions: The DUT is switched ON for 1 minute and then OFF for 1 minute
<b>Dry Heat Test DHT</b>	Standard: IEC 680068-2-2, Test Bb
	Special conditions: <ul style="list-style-type: none"> <li>• Temperature: +85°C</li> <li>• Rate of temperature change: dT/dt &gt;= ± 3°C/min</li> <li>• Recovery time: 3 hours</li> </ul>
	Operating conditions: Un-powered

Designation	Condition
	Duration: 72 hours

### 8.3.2.2.3. Corrosive Resistance Stress Test

The following tests the FXTE02's resistance to corrosive atmosphere.

Table 40: Corrosive Resistance Stress Test

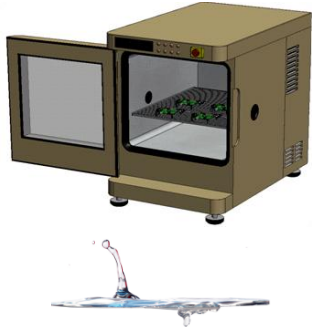
Designation	Condition
<b>Humidity Test HT</b> 	Standard: IEC 60068-2-3 Special conditions: <ul style="list-style-type: none"> <li>• Temperature: +65°C</li> <li>• RH: 95%</li> <li>• Rate of temperature change: <math>dT/dt \geq \pm 3^\circ\text{C}/\text{min}</math></li> <li>• Recovery time: 3 hours</li> </ul> Operating conditions: The DUT is switched ON for 5 minutes and then OFF for 15 minutes Duration: 10 days

### 8.3.2.2.4. Thermal Resistance Cycle Stress Test

The following tests the FXTE02's resistance to extreme temperature cycling.

Table 41: Thermal Resistance Cycle Stress Test

Designation	Condition
<b>Thermal Shock Test TSKT</b> 	Standard: IEC 60068-2-14 Special conditions: <ul style="list-style-type: none"> <li>• Upper temperature: +85°C</li> <li>• Lower temperature: -40°C</li> <li>• Rate of temperature change: 30s</li> <li>• Number of cycles: 200</li> <li>• Duration of exposure: 30 minutes</li> <li>• Recovery time: 3 hours</li> </ul> Operating conditions: Un-powered Duration: 72 hours

### 8.3.2.2.5. Mechanical Resistance Stress Tests

The following tests the FXTE02's resistance to vibrations and mechanical shocks.

Table 42: Mechanical Resistance Stress Tests

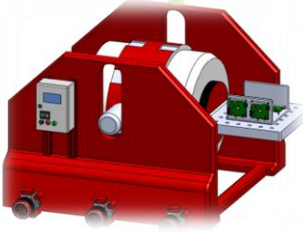
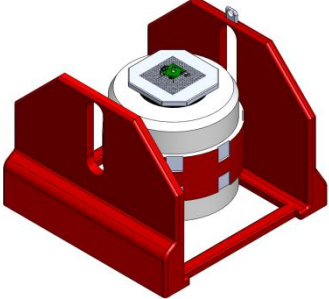
Designation	Condition
<p><b>Sinusoidal Vibration Test SVT</b></p> 	<p>Standard: IEC 60068-2-6, Test Fc</p> <p>Special conditions:</p> <ul style="list-style-type: none"> <li>• Frequency range: 10Hz to 1000Hz                             <ul style="list-style-type: none"> <li>▪ Displacement: ±5mm (peak)</li> </ul> </li> <li>• Frequency range: 16Hz to 62Hz                             <ul style="list-style-type: none"> <li>▪ Acceleration: 5G</li> </ul> </li> <li>• Frequency range: 62Hz to 200Hz                             <ul style="list-style-type: none"> <li>▪ Acceleration: 3G</li> </ul> </li> <li>• Frequency range: 200Hz to 1000Hz                             <ul style="list-style-type: none"> <li>▪ Acceleration: 1G</li> </ul> </li> <li>• Sweep rate: 1 oct/min.</li> <li>• Test duration: 20 cycles</li> <li>• Sweep directions: X, Y and Z</li> </ul> <p>Operating conditions: Un-powered</p> <p>Duration: 72 hours</p>
<p><b>Random Vibration Test RVT</b></p> 	<p>Standard: IEC 60068-2-64</p> <p>Special conditions:</p> <ul style="list-style-type: none"> <li>• Density spectrum: 0.96m<sup>2</sup>/s<sup>3</sup></li> <li>• Frequency range:                             <ul style="list-style-type: none"> <li>▪ 0.1 g<sup>2</sup>/Hz at 10Hz</li> <li>▪ 0.01 g<sup>2</sup>/Hz at 250Hz</li> <li>▪ 0.0005 g<sup>2</sup>/Hz at 1000Hz</li> <li>▪ 0.0005 g<sup>2</sup>/Hz at 2000Hz</li> </ul> </li> <li>• Slope: -3dB/octave</li> <li>• Acceleration: 0.9gRMS</li> <li>• Number of axis: 3</li> </ul> <p>Operating conditions: Un-powered</p> <p>Duration: 16 hours</p>
<p><b>Mechanical Shock Test MST</b></p> 	<p>Standard: IEC 60068-2-27, Test Ea</p> <p>Special conditions:</p> <ul style="list-style-type: none"> <li>• Wave form: Half sine</li> <li>• Peak acceleration: 50G</li> <li>• Duration: 11ms</li> <li>• Number of shocks: 3 per direction</li> <li>• Number of directions: 6 (±X, ±Y, ±Z)</li> </ul> <p>Operating conditions: Un-powered</p> <p>Duration: 12 hours</p>

### 8.3.2.2.6. Handling Resistance Stress Tests

The following tests the FXTE02's resistance to handling malfunctions and damage.

Table 43: Handling Resistance Stress Tests

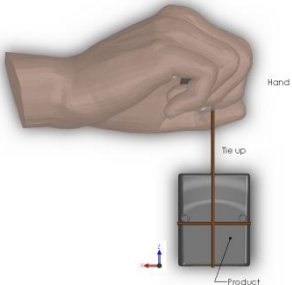
Designation	Condition
<p><b>ESD Test</b></p> 	<p>Standard: IEC 1000-4-2</p> <p>Special conditions:</p> <ul style="list-style-type: none"> <li>• Contact discharges: 10 positive and 10 negative applied</li> <li>• Voltage: <math>\pm 1\text{kV}</math>, <math>\pm 2\text{kV}</math></li> </ul> <p>Operating conditions: Powered</p> <p>Duration: 12 hours</p>
<p><b>Operational Durability OD</b></p>	<p>Standard: N/A</p> <p>Special conditions:</p> <ul style="list-style-type: none"> <li>• SIM Connector:                             <ul style="list-style-type: none"> <li>▪ Cycles: 40</li> <li>▪ Repetition Rate: 3s per cycle</li> <li>▪ Objective: Mating and de-mating</li> </ul> </li> <li>• System Connector:                             <ul style="list-style-type: none"> <li>▪ Cycles: 40</li> <li>▪ Repetition Rate: 3s per cycle</li> <li>▪ Objective: Mating and de-mating</li> </ul> </li> <li>• RF Connector:                             <ul style="list-style-type: none"> <li>▪ Cycles: 20</li> <li>▪ Repetition Rate: 5s per cycle</li> <li>▪ Objective: Mating and de-mating</li> </ul> </li> </ul> <p>Operating conditions: Un-powered</p> <p>Duration: 24 hours</p>
<p><b>Free Fall Test FFT</b></p> 	<p>Standard : IEC 60068-2-32, Test Ed</p> <p>Special conditions:</p> <ul style="list-style-type: none"> <li>• Drop: 2 samples for each direction</li> <li>• Equivalent drop height: 1.5m</li> <li>• Number of directions: 6 (<math>\pm X</math>, <math>\pm Y</math>, <math>\pm Z</math>)</li> <li>• Number of drops/face: 2</li> </ul> <p>Operating conditions: Un-powered</p> <p>Duration: 24 hours</p>



## 9. Certification Compliance and Recommended Standards

### 9.1. Certification Compliance

The Expansion Card is compliant with the following requirements.

Table 44: Standards Conformity for the Expansion Card

Domain	Applicable Standard
Safety standard	EN 60950-1 (ed.2006)
Health standard (EMF Exposure Evaluation)	EN 62311 (ed. 2008)
Efficient use of the radio frequency spectrum	EN 301 511 (V 9.0.2)
EMC	EN 301 489-1 (v1.8.1) EN 301 489-7 (v1.3.1) EN 301 489-24 (v1.4.1)
FCC	FCC Part 15 FCC Part 22, 24
IC	RSS-132 Issue 2 RSS-133 Issue 5

### 9.2. Applicable Standards Listing

The table hereafter gives the basic list of standards applicable for 2G and WCDMA (Rel. 5 to 7).

*Note: References to any features can be found from these standards.*

Table 45: Applicable Standards and Requirements for the Expansion Card

Document	Current Version	Title
GCF	3.7.1	GSM Certification Forum - Certification Criteria
NAPRD.03	2.6.0	Overview of PCS Type certification review board (PTCRB) Mobile Equipment Type Certification and IMEI control
TS 51.010-1	8.3.0	3rd Generation Partnership Project; Technical Specification Group GSM/EDGE Radio Access Network; Digital cellular telecommunications system (Phase 2+); Mobile Station (MS) conformance specification; Part 1: Conformance specification
TS 51.010-2	8.3.0	3rd Generation Partnership Project; Technical Specification Group GSM/EDGE Radio Access Network; Mobile Station (MS) conformance specification; Part 2: Protocol Implementation Conformance Statement (PICS) proforma specification
TS 51.010-4	4.14.1	3rd Generation Partnership Project; Technical Specification Group GSM/EDGE Radio Access Network; Digital cellular telecommunications system (Phase 2+); Mobile Station (MS) conformance specification; Part 4: SIM Application Toolkit Conformance specification
EN 301 511	9.0.2	Global System for Mobile Communications (GSM); Harmonised standard for mobile stations in the GSM 900 and DCS 1800 bands covering essential requirements under article 3.2 of the R&TTE directive (1999/5/EC)

<b>Document</b>	<b>Current Version</b>	<b>Title</b>
TS 34.121-1	8.5.0	3rd Generation Partnership Project; Technical Specification Group Radio Access Network; User Equipment (UE) conformance specification; Radio transmission and reception (FDD); Part 1: Conformance specification
TS 34.121-2	8.5.0	3rd Generation Partnership Project; Technical Specification Group Radio Access Network User Equipment (UE) conformance specification; Radio transmission and reception (FDD); Part 2: Implementation Conformance Statement (ICS)
TS 34.123-1	8.5.0	3rd Generation Partnership Project; Technical Specification Group Terminals; User Equipment (UE) conformance specification; Part 1: Protocol conformance specification

## 10. Connector and Peripheral Devices References

This section contains a list of recommended manufacturers or suppliers for the peripheral devices to be used with the Expansion Card.

For more information, refer to the following websites:

- Kyocera Elco: <http://www.kyocera-elco.com/>
- Hirose: <http://www.hirose.com/>
- AVX Corp: <http://www.avx.com/>

### 10.1. General Purpose Connector

---

*Note:* This connector is used in both FXTE01 and FXTE02.

---

The GPC is a 50-pin plug connector with 0.5mm pitch from Kyocera Elco with the following reference:

- 14 5078 050 515 861+

### 10.2. 16-way I/O Socket (for FXTE01)

The 16-way IO Socket has a 0.625mm pitch and is from Kyocera Elco with the following reference:

- 20 9257 016 001 013 (Expansion Card side)

### 10.3. 16-way I/O Plug (for FXTE01)

The 16-way IO plug has a 0.625mm pitch and is from Kyocera Elco with the following reference:

- 58 9257 000 000 012S

### 10.4. 10-pin Socket (for FXTE02)

The 10-pin socket with 0.5mm pitch is from Hirose and has the following reference:

- ST60-10P



## 11. Recommended Accessories

The following table lists the accessories recommended by Sierra Wireless for use with the Expansion Card.

Table 46: Recommended Accessories

Expansion Card Type	Accessory	Part Number/Reference	Supplier
FXTE01	GPS antenna with MMCX connector	GC-GAACZ-A55	GIGA-Concept

## 12. Reference Documents

For more details, several reference documents can be consulted. The Sierra Wireless documents referenced herein are provided in the Sierra Wireless documentation package; however, the general reference documents which are not Sierra Wireless owned are not provided in the documentation package.

### 12.1. Sierra Wireless Software Documentation

- [1] Getting Started with Sierra Wireless Software Suite 2.02a (Official)  
Reference: WM\_DEV\_OAT\_UGD\_058
- [2] Tutorial for IDE 1.08 (if using IDE; obsolete if using Developer Studio)  
Reference: WM\_DEV\_OAT\_UGD\_044
- [3] Tools Manual for IDE 1.08 (if using IDE; obsolete if using Developer Studio)  
Reference: WM\_DEV\_OAT\_UGD\_045
- [4] Basic Development Guide for SDK 4.22 (if using IDE; obsolete if using Developer Studio)  
Reference: WM\_DEV\_OAT\_UGD\_050
- [5] ADL User Guide for Open AT<sup>®</sup> OS 6.02 (for Sierra Wireless Software Suite 2.02)  
Reference: WM\_DEV\_OAT\_UGD\_060

### 12.2. Firmware Documentation

- [6] Firmware 7.1b AT Commands Manual (for Sierra Wireless Software Suite 2.02a)  
Reference: WM\_DEV\_OAT\_UGD\_059
- [7] Firmware 7.1 Customer Release Note  
Reference: WM\_PGM\_OAT\_CRN\_012

### 12.3. AirLink FXT Series Documentation

- [8] AirLink FXT Series User Guide  
Reference: WA\_DEV\_FEX20\_UGD\_002

### 12.4. Expansion Card Documentation

- [9] FXTE01 and FXTE02 Installation Guide  
Reference: WA\_DEV\_FEX20\_UGD\_009

## >> 13. List of Abbreviations

Abbreviation	Definition
AC	Alternating Current
ACM	Accumulated Call Meter
AT	ATtention (prefix for Wireless CPU <sup>®</sup> commands)
CLK	CLock
CMOS	Complementary Metal Oxide Semiconductor
CS	Coding Scheme
CTS	Clear To Send
dB	Decibel
dBc	Decibel relative to the Carrier power
dB <sub>i</sub>	Decibel relative to an Isotropic radiator
dB <sub>m</sub>	Decibel relative to one milliwatt
DC	Direct Current
DCD	Data Carrier Detect
DCE	Data Communication Equipment
DCS	Digital Cellular System
DSR	Data Set Ready
DTE	Data Terminal Equipment
DTMF	Dual Tone Multi-Frequency
DTR	Data Terminal Ready
EEPROM	Electrically Erasable Programmable Read-Only Memory
EFR	Enhanced Full Rate
E-GSM	Extended GSM
EMC	ElectroMagnetic Compatibility
EMI	ElectroMagnetic Interference
ESD	ElectroStatic Discharges
ETSI	European Telecommunications Standards Institute
FIT	Series of connectors (micro-FIT)
FR	Full Rate
FTA	Full Type Approval
GCF	Global Certification Forum
GND	GrouND
GPIO	General Purpose Input Output
GPRS	General Packet Radio Service
GPS	Global Positioning System
GSM	Global System for Mobile communications
HR	Half Rate
I	Input
IEC	International Electrotechnical Commission
IES	Internal Expansion Socket
IESM	Internal Expansion Socket Module
IMEI	International Mobile Equipment Identification

Abbreviation	Definition
I/O	Input / Output
LED	Light Emitting Diode
MAX	MAXimum
ME	Mobile Equipment
MIC	MICrophone
Micro-Fit	Family of connectors from Molex
MIN	MINimum
MNP	Microcom Networking Protocol
MO	Mobile Originated
MS	Mobile Station
MT	Mobile Terminated
NOM	NOMinal
O	Output
Pa	Pascal (for speaker sound pressure measurements)
PBCCH	Packet Broadcast Control CHannel
PC	Personal Computer
PCL	Power Control Level
PDP	Packet Data Protocol
PIN	Personal Identity Number
PLMN	Public Land Mobile Network
PUK	Personal Unblocking Key
RF	Radio Frequency
RFI	Radio Frequency Interference
RI	Ring Indicator
RMS	Root Mean Square
RTS	Request To Send
RX	Receive
SIM	Subscriber Identification Module
SMA	SubMiniature version A RF connector
SMS	Short Message Service
SNR	Signal-to-Noise Ratio
SPL	Sound Pressure Level
SPK	SpeaKer
SRAM	Static RAM
TCP/IP	Transmission Control Protocol / Internet Protocol
TDMA	Time Division Multiple Access
TU	Typical Urban fading profile
TUHigh	Typical Urban, High speed fading profile
TX	Transmit
TYP	TYPical
USB	Universal Serial Bus
VSWR	Voltage Stationary Wave Ratio



## 14. Safety Recommendations (for Information Only)

For the efficient and safe operation of your GSM device, please read the following information carefully.

### 14.1. RF Safety

#### 14.1.1. General

Your GSM terminal is based on the GSM standard for cellular technology. The GSM standard is spread all over the world. It covers Europe, Asia and some parts of America and Africa. This is the most used telecommunication standard.

Your GSM terminal is actually a low power radio transmitter and receiver. It sends out and receives radio frequency energy. When you use your GSM application, the cellular system which handles your calls controls both the radio frequency and the power level of your cellular modem.

#### 14.1.2. Exposure to RF Energy

There has been some public concern about possible health effects of using GSM terminals. Although research on health effects from RF energy has focused on the current RF technology for many years, scientists have begun research regarding newer radio technologies, such as GSM. After existing research had been reviewed, and after compliance to all applicable safety standards had been tested, it has been concluded that the product was fitted for use.

If you are concerned about exposure to RF energy there are things you can do to minimize exposure. Obviously, limiting the duration of your calls will reduce your exposure to RF energy. In addition, you can reduce RF exposure by operating your cellular terminal efficiently by following the below guidelines.

#### 14.1.3. Efficient Terminal Operation

For your GSM terminal to operate at the lowest power level, consistent with satisfactory call quality:

If your terminal has an extendible antenna, extend it fully. Some models allow you to place a call with the antenna retracted. However your GSM terminal operates more efficiently with the antenna fully extended.

Do not hold the antenna when the terminal is « IN USE ». Holding the antenna affects call quality and may cause the modem to operate at a higher power level than needed.

#### 14.1.4. Antenna Care and Replacement

Do not use the GSM terminal with a damaged antenna. If a damaged antenna comes into contact with the skin, a minor burn may result. Replace a damaged antenna immediately. Consult your manual to see if you may change the antenna yourself. If so, use only a manufacturer-approved antenna. Otherwise, have your antenna repaired by a qualified technician.

Use only the supplied or approved antenna. Unauthorized antennas, modifications or attachments could damage the terminal and may contravene local RF emission regulations or invalidate type approval.

When installing the coaxial cable to the Fastrack Xtend, it is necessary to ensure that the metal shield is reliably connected to the protective earthing system of the building. The coaxial cable shield shall be connected to the grounded system of the building, as close to the point of cable entry as practical.

## 14.2. General Safety

### 14.2.1. Driving

Check the laws and the regulations regarding the use of cellular devices in the area where you have to drive as you always have to comply with them. When using your GSM terminal while driving, please:

- give full attention to driving,
- pull off the road and park before making or answering a call if driving conditions so require.

### 14.2.2. Electronic Devices

Most electronic equipment, for example in hospitals and motor vehicles is shielded from RF energy. However RF energy may affect some improperly shielded electronic equipment.

### 14.2.3. Vehicle Electronic Equipment

Check your vehicle manufacturer representative to determine if any on-board electronic equipment is adequately shielded from RF energy.

### 14.2.4. Medical Electronic Equipment

Consult the manufacturer of any personal medical devices (such as pacemakers, hearing aids, etc...) to determine if they are adequately shielded from external RF energy.

Turn your terminal OFF in health care facilities when any regulations posted in the area instruct you to do so. Hospitals or health care facilities may be using RF monitoring equipment.

### 14.2.5. Aircraft

Turn your terminal OFF before boarding any aircraft.

- Use it on the ground only with crew permission
- Do not use it in the air

To prevent possible interference with aircraft systems, Federal Aviation Administration (FAA) regulations require you to have permission from a crew member to use your terminal while the aircraft is on the ground. To prevent interference with cellular systems, local RF regulations prohibit using your modem while airborne.

## 14.2.6. Children

Do not allow children to play with your GSM terminal. It is not a toy. Children could hurt themselves or others (by poking themselves or others in the eye with the antenna, for example). Children could damage the modem, or make calls that increase your modem bills.

## 14.2.7. Blasting Areas

To avoid interfering with blasting operations, turn your unit OFF when in a « blasting area » or in areas posted : « turn off two-way radio ». Construction crews often use remote control RF devices to set off explosives.

## 14.2.8. Potentially Explosive Atmospheres

Turn your terminal OFF when in any area with a potentially explosive atmosphere. It is rare, but your modem or its accessories could generate sparks. Sparks in such areas could cause an explosion or fire resulting in bodily injuries or even death.

Areas with a potentially explosive atmosphere are often, but not always, clearly marked. They include fuelling areas such as petrol stations; below decks on boats; fuel or chemical transfer or storage facilities; and areas where the air contains chemicals or particles, such as grain, dust, or metal powders.

Do not transport or store flammable gas, liquid, or explosives, in the compartment of your vehicle which contains your terminal or accessories.

Before using your terminal in a vehicle powered by liquefied petroleum gas (such as propane or butane) ensure that the vehicle complies with the relevant fire and safety regulations of the country in which the vehicle is to be used.

# >> 15. Appendix A: Packaging

## 15.1. Contents

### 15.1.1. FXTE01: IO+GPS Expansion Card

The Ethernet Expansion Card package contains the following:

- 100 pieces Ethernet Expansion Cards
- 100 pieces Backplate and Spring Contacts
- 3 pieces Extraction Tool
- Installation Guide



**FXTE01 Expansion Cards**



**Backplate and Spring Contacts**





**Extraction Tool**

## 15.1.2. FXTE02: Ethernet Expansion Card

The Ethernet Expansion Card package contains the following:

- 100 pieces Ethernet Expansion Cards
- 100 pieces Backplate and Spring Contacts
- 100 pieces RJ45 Interface Cable
- 3 pieces Extraction Tool
- Installation Guide

	
<p><b>Ethernet Expansion Cards</b></p>	<p><b>Backplate and Spring Contacts</b></p>
	
<p><b>RJ45 Interface Cable</b></p>	<p><b>Extraction Tool</b></p>

## 15.2. Packaging Box

The packaging box of the Expansion Card has the following physical dimensions:

- Width: 295 mm
- Height: 65 mm
- Length: 515 mm

The label on the top of the packaging box indicates the following:

- Sierra Wireless Logo
- Product Reference (IO+GPS or Ethernet Expansion Card)
- CE Mark
- RoHS Logo

## 15.3. Production Stickers

Production and MAC address stickers (refer to the following figures) are located at the back of the Expansion Cards, and contains the following information:

- Product Name (IO+GPS or Ethernet Expansion Card)
- Marketing Name (FXTE01 or FXTE02)
- Barcode
- 17-digit Serial Number
- MAC Address (FXTE02 only)



Figure 15. Product Name and Serial Number Sticker



Figure 16. MAC Address Sticker



**SIERRA**  
WIRELESS